



ECM-6103

COM-Express Type6 核心板
USER Manual V2.1

USER MANUAL 用户手册

声明

本使用说明书内容如有变更，恕不另行通知。本公司并不对本使用说明书之适用性，适合做某种特殊用途之使用或其他任何事项做任何明示，或做其他形式之保证或担保。因此本公司将不对手册内容之错误，或因增减展示或以其他方式使用本手册所造成之直接，间接，突发性过、或继发性之损害负任何责任。

版权声明：

版权所有----深圳智锐通科技有限公司。未经本公司许可或依著作权法之规定许准，不得复制，节录和翻译使用说明书之任何内容。

安全须知

| | |
|----|--|
| 1 | 产品使用前，务必仔细阅读产品说明书。 |
| 2 | 对未准备安装的板卡，应将其保存在防静电保护袋中。 |
| 3 | 在从包装袋中拿板卡前，应将手先置于接地金属物体上一会儿，以释放身体及手中的静电。 |
| 4 | 在拿板卡时，需佩带静电保护手套，并且应该养成只触及其边缘部份的习惯。 |
| 5 | 主板与电源连接时，请确认电源电压。 |
| 6 | 为避免人本被电击或产品被损坏，在每次对主板、板卡进行拔插或生新配置时须先关闭交流电源或将交流电源线从电源插座中拔掉。 |
| 7 | 在对板卡进行搬动前，先将交流电源线从电源插座中拔掉。 |
| 8 | 当您需连接或拔除任何设备前，须确定所有的电源线事先已被拔掉。 |
| 9 | 为避免频繁开关机对产品造成不必要的损伤,关机后,应至少等待30秒后再开机。 |
| 10 | 设备在使用过程时出现异常情况，请找专业人员处理。 |

目录

| | |
|--|----|
| 第一章 产品介绍 | 6 |
| 1.1 产品规格 | 6 |
| 1.2 功能框图 | 8 |
| 1.3 产品料号 | 9 |
| 1.4 产品照片 | 9 |
| 1.5 散热器 | 10 |
| 1.6 安装视频 | 10 |
| 第二章 安装说明 | 11 |
| 2.1 接口/尺寸图 | 11 |
| 2.2 硬件安装 | 12 |
| 2.3 跳线功能设置 | 12 |
| 2.4 接口引脚定义 | 12 |
| 2.4.1 CPU_FAN1 引脚定义 | 12 |
| 2.4.2 SW1 引脚设定 (IT8659 Power-On Strapping) | 12 |
| 2.4.3 COMe 220Pin 引脚定义 | 13 |
| 第三章 BIOS 程序设置 | 17 |
| 3.1 Main Screen | 18 |
| 3.2 Advanced Screen | 20 |
| 3.2.1 CPU Configuration Screen | 21 |
| 3.2.2 ACPI Settings Screen | 24 |
| 3.2.3 Super IO Configuration | 25 |
| 3.2.3.1 Serial PortX Configuration | 26 |

| | |
|--|-----------|
| 3.2.4 Hardware Monitor | 27 |
| 3.2.5 SATA Configuration | 28 |
| 3.2.6 USB Configuration | 29 |
| 3.2.7 Network Stack Configuration..... | 31 |
| 3.2.8 CSM Configuration | 32 |
| 3.2.9 Watchdog Configuration | 33 |
| 3.2.10 LVDS Panel..... | 34 |
| 3.3 Chipset Screen | 35 |
| 3.3.1 System Agent (SA) Configuration | 36 |
| 3.3.2 PCH-IO Configuration | 39 |
| 3.4 Security..... | 40 |
| 3.5 Boot Screen..... | 41 |
| 3.6 Save & Exit Screen..... | 43 |
| 第四章 Electrical Specifications | 45 |
| 4.1 Input Power - General Considerations | 45 |
| 4.2 Input Power - Current Load | 46 |
| 4.3 Input Power - Sequencing..... | 47 |
| 4.4 Input Power - Rise Time | 48 |
| 4.5 Signal Integrity Requirements..... | 49 |
| 附录..... | 50 |
| 附一：术语表..... | 50 |

第一章 产品介绍

1.1 产品规格

| Model | | ECM-6103 | | |
|-------------------------|-----------------------------------|---|-----------|------------|
| 配置 Item | 规格 Specification | 描述 Describe | | |
| 处理器 Processor System | 处理器 CPU | i7-11850HE | i5-11500H | i3-11100HE |
| | 内核数 Core Number | 8 | 6 | 4 |
| | 最高主频 Max. Speed | 4.7GHz | 4.5GHz | 4.4GHz |
| | 二级缓存 L2 Cache | 24M | 12M | 8M |
| | 功耗 TDP (W) | 45W | 45W | 45W |
| | 芯片组 Chipset | QM580E/WM590 | | |
| | 指令集 Instruction Set Extensions | SSE4.1, SSE4.2, AVX2, AVX-512 | | |
| | BIOS | AMI EFI 256Mbit | | |
| 扩展插槽 Expansion Slot | PCI Express x16 | PCI Express Gen4(8.0 GT/s) 1*PCIe x16 可配置成 1x16, 2x8, 1x8+2x4 | | |
| | PCI Express x1 | PCI Express Gen3 8*PCIe x1, 可配置成 x4 或 x2 | | |
| 内存 Memory | 规格 Technology | DDR4(ECC support by specific SKU) | | |
| | 最大容量 Max. Capacity | 64G 3200MHz | | |
| | 插槽 Socket | 2*SO-DIMM | | |
| 显示 Display | 控制器 Controller | 3*DDI support configurable HDMI/DVI/DP 1*DDI support configurable VGA 1*eDP to LVDS(optional eDP) | | |
| | 分辨率 Resolution | VGA: 1920*1200@60Hz LVDS dual channel: 1920*1200@60Hz eDP: 4096*2304@60Hz, 24bpp HDMI: 4096*2160@24Hz DVI: 1920*1200@60Hz DP: 4096*2304@60Hz | | |

| | | |
|-------------------------------|-----------------------|---|
| 以太网 Ethernet | 控制器 Controller | Intel i225LM/IT(up to 2.5GbE) |
| | 连接器 Connector | COMe |
| I/O | GPIO | 8-bit GPIO |
| | SER | 2*SER |
| 内部接口 Internal Connector | USB 3.2 | 4*USB3.2 |
| | USB 2.0 | 8*USB2.0 |
| | 音频 Audio | 1*HDA |
| | SATA 3.0 | 4*SATA3.0 |
| | LPC | 1*LPC |
| | SMBUS | 1*SMBUS |
| | 看门狗 Watch Dog | Support |
| | TPM2.0 | 1*TPM2.0 |
| | 按钮 Button | 1*Power Button 1*Reset Button |
| | 其他 Others | Smart Fan 2 Ports (1 port on COM module (Notice: the input voltage of fan is aligned to Vin); 1 port on carrier board) |
| | 拓展 | 2*COM-E 220Pin |
| 电源 Power Requirements | 电源类型 Power Type | ATX: VCC, VSB AT: VCC |
| | 电源电压 Input Voltage | Supply Voltage Vin: 8.5V~20V VSB: 4.75V~5.25 V RTC Battery: 2.0V~3.3V |
| | 连接器 Connector type | 底板供电 |
| 物理特性 Physical | 尺寸 Dimensions | 125*95*2.0mm |
| | PCB 颜色 Color | Green |

| | | |
|-------------------|-------------------------------|--|
| 环境 Environment | 工作温度 Operating Temperature | 0~60°C |
| | 存储温度 Storage Temperature | -40~85°C |
| | 工作湿度 Operating Humidity | 20~90%(non-condensing) |
| 操作系统 OS | Microsoft | Windows 10 LTSC/1809(RS5) |
| | Linux | Red Hat 8.4 Ubuntu 20.04 Yocto 4.0xLTS |

1.2 功能框图

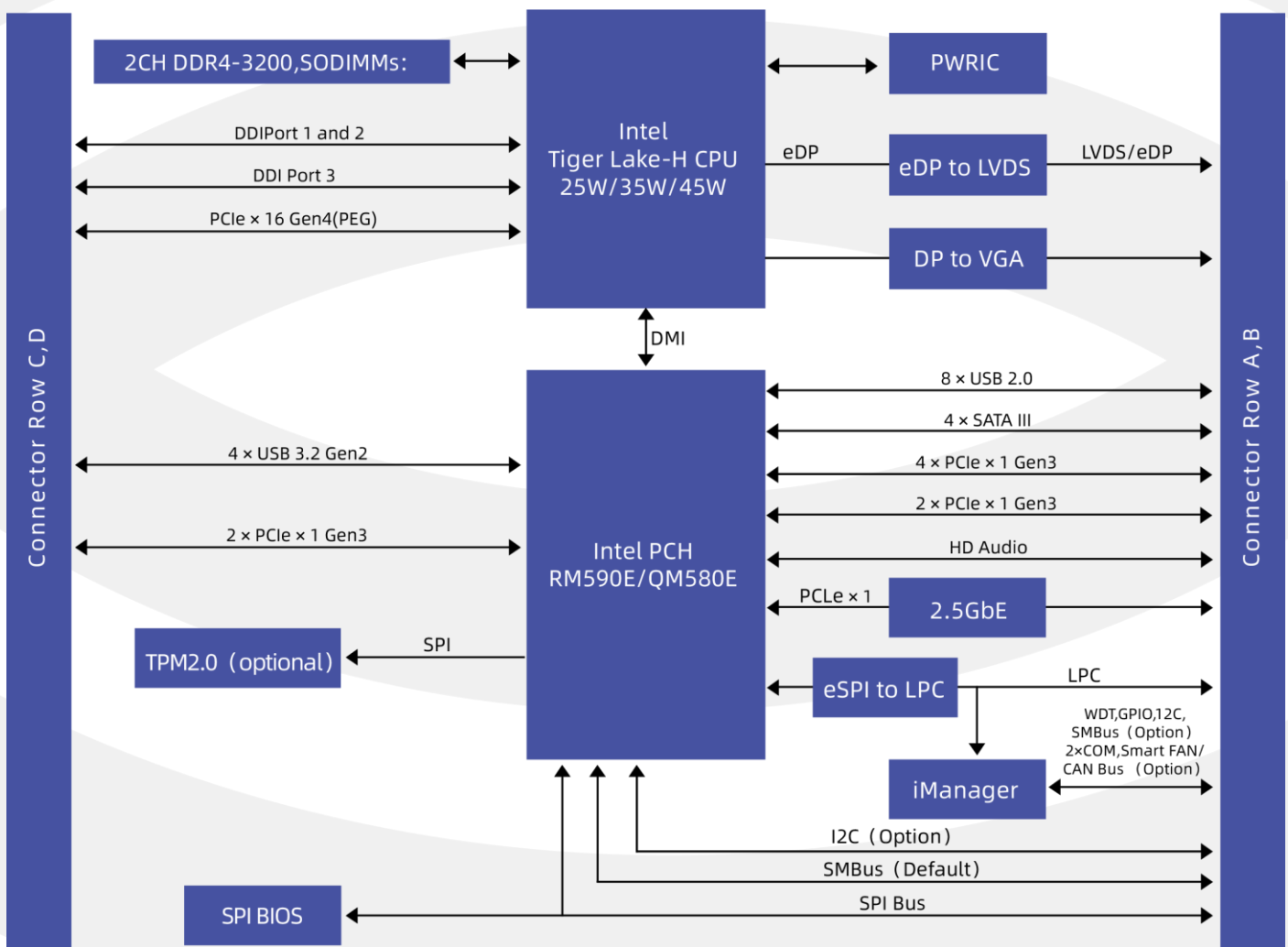

1.3 产品料号

| Model | Part Number | Specification |
|----------|----------------------|--|
| ECM-6103 | 8.ZRT.80-1621-10-LFF | ECM-6103,VER 1.1,COME 核心板,11 代 Tigerlake-H,i7-11850H+WM590 DDR4 SODIMM+IT8659+IT8883+LVDS,工包装二十入 |
| | 8.ZRT.80-1621-08-LFF | 核心板-COMe ECM-6103,VER 1.1,COME 核心板,11 代 Tigerlake-H,i7-11850H+WM590 DDR4 SODIMM+IT8659+IT8883+LVDS,主板带散热器,工包装二十入 |
| | 8.ZRT.80-1621-07-LFF | 核心板-COMe ECM-6103,VER 1.1,COME 核心板,11 代 Tigerlake-H,i5-11500H+WM590 DDR4 SODIMM+IT8659+IT8883+LVDS,主板带散热器,工包装二十入 |
| | 8.ZRT.80-1621-09-LFF | 核心板-COMe ECM-6103,VER 1.1,COME 核心板,11 代 Tigerlake-H,i3-11100HE+QM580E DDR4 SODIMM+IT8659+IT8883+LVDS,主板带散热器,工包装二十入 |

1.4 产品照片

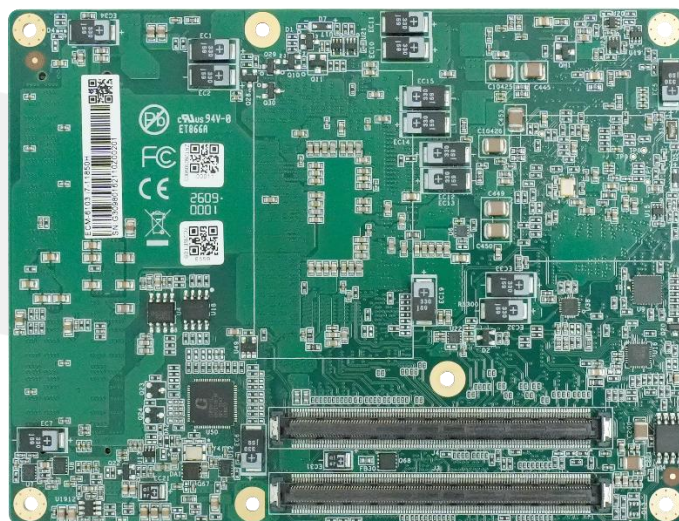
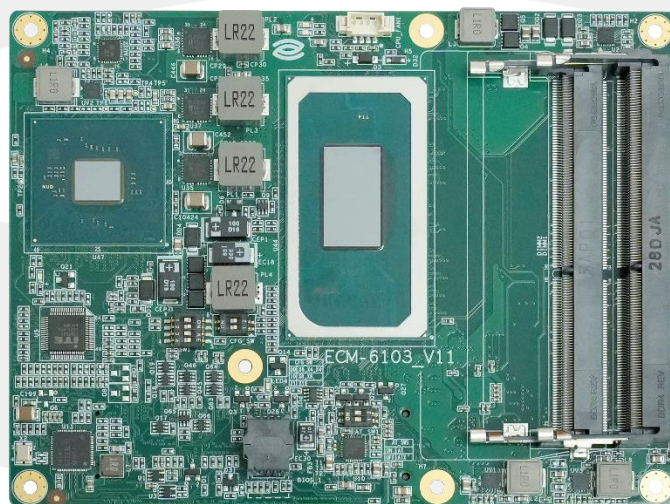

1.5 散热器

Part Number: 1.ZRT.48-6331-00-A00

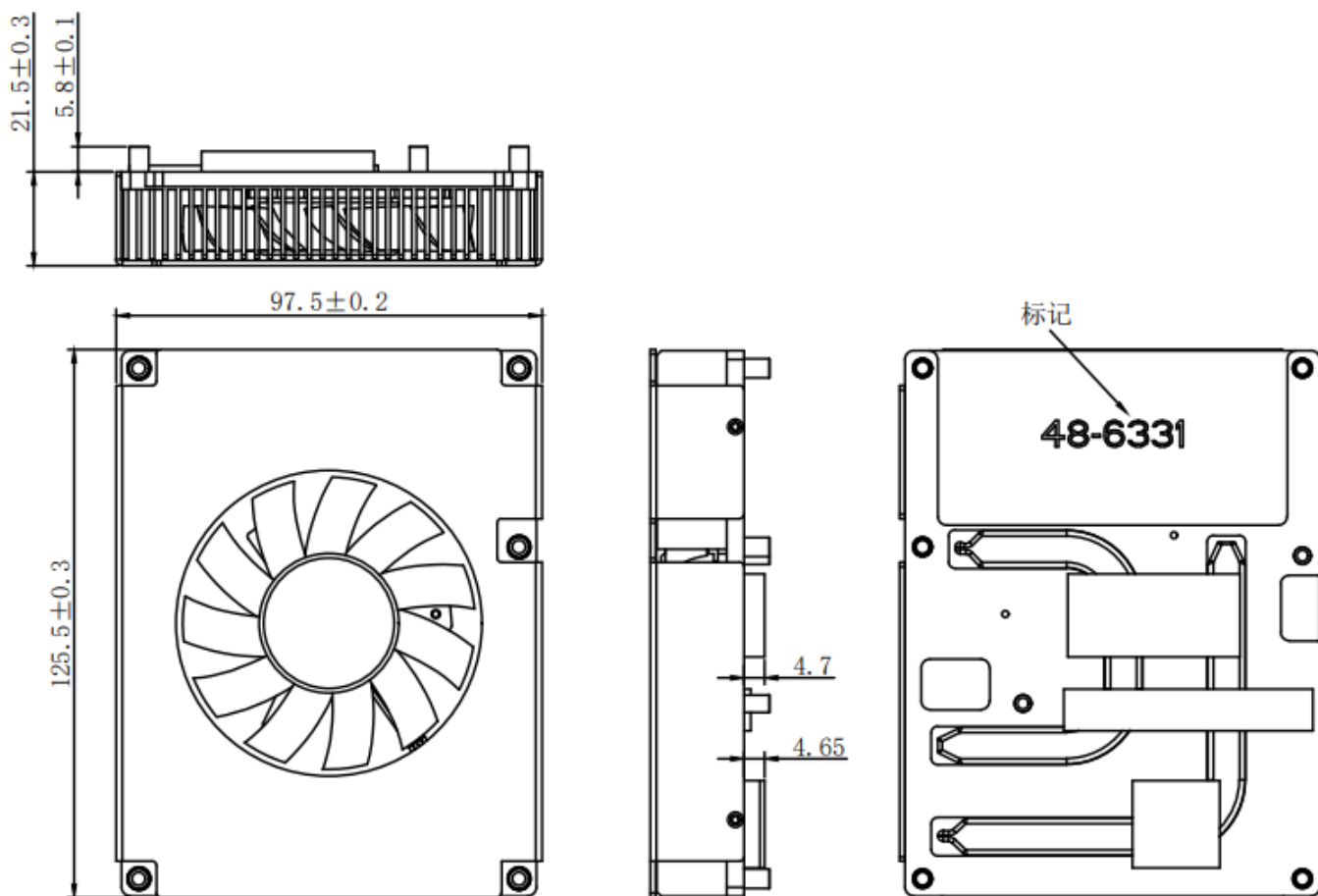
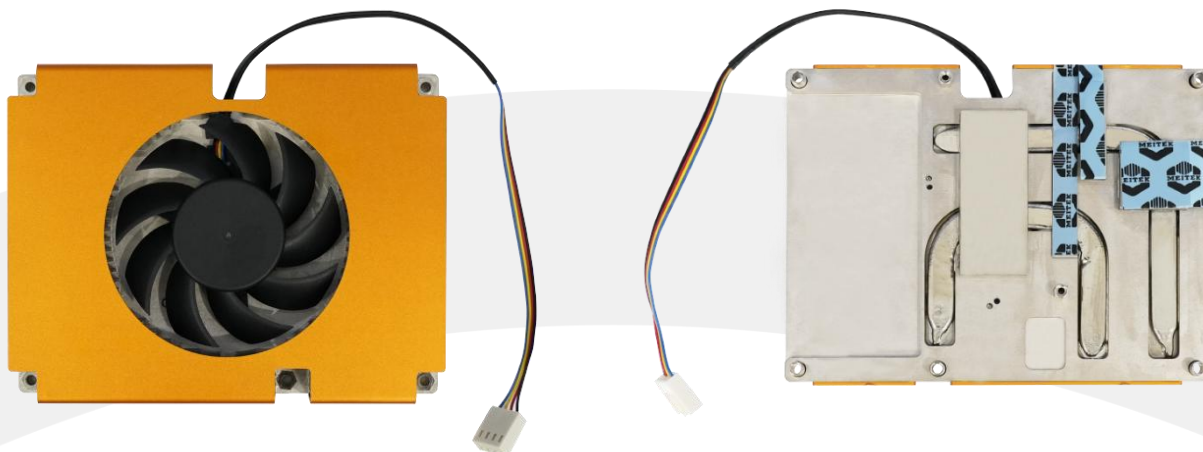

1.6 安装视频

https://www.douyin.com/user/MS4wLjABAAAfV567McP9KjHrjFWngJgFG8h7XMSWsqH55hBlryutm?from_tab_name=main&modal_id=7429655415694052618

第二章 安装说明

2.1 接口/尺寸图

安装设备时, 请对照此示意图并详细阅读下面的说明, 安装组件过程中必须小心, 对于有些部件, 如果安装不正确, 设备将不能正常工作。

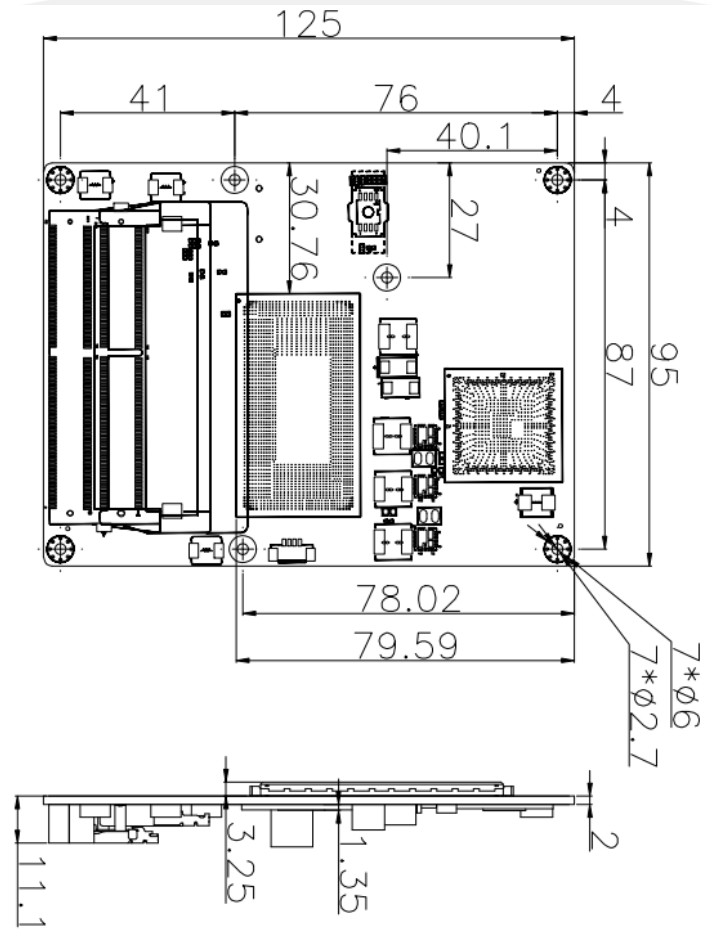

TOP Side

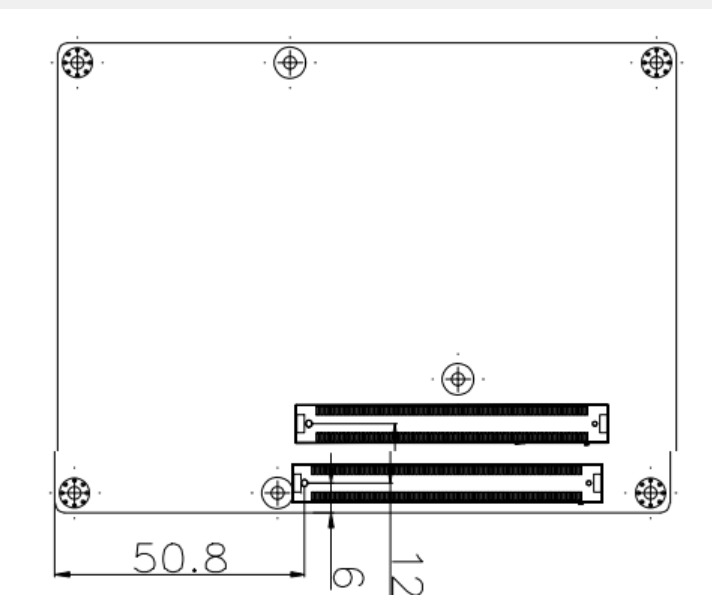

Bottom Side

2.2 硬件安装

⚠ 注意：操作时，请戴上防静电手套，因为静电有可能会损坏部件。

本主板关键元器件都是集成电路，而这些元件很容易因为遭受静电的影响而损坏。因此，请在正式安装主板之前，请先做好以下的准备：

1. 拿主板时手握板边，尽可能不触及元器件和插头插座的引脚。
2. 接触集成电路元件(如 CPU、RAM 等)时，最好戴上防静电手环/手套。
3. 在集成电路元件未安装前，需将元件放在防静电垫或防静电袋内。
4. 在确认电源的开关处于断开位置后，再插上电源插头。

2.3 跳线功能设置

在进行硬件设备安装之前，请按照您的需要对相应的跳线进行设置。

提示：如何识别跳线、接口的第 1 针脚，观察插头插座旁边的文字标记，会用“1”或加粗的线条或三角符号表示；看看背面的焊盘，方型焊盘为第 1 针脚；所有跳线的针脚 1 旁都有 1 个白色箭头。

2.4 接口引脚定义

2.4.1 CPU_FAN1 引脚定义

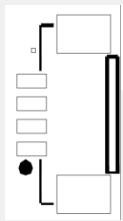

| 管脚 | 电平设定 |
|----|---------|
| 1 | GND |
| 2 | 5V |
| 3 | FAN_TAC |
| 4 | FAN_CTL |

2.4.2 SW1 引脚设定(IT8659 Power-On Strapping)

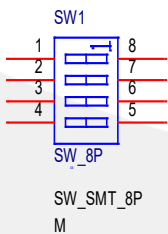

| 管脚 | 电平设定 |
|----|------------|
| 1 | 拨码到 1(VCC) |
| 2 | 拨码到 2(GND) |
| 3 | 拨码到 3(VCC) |
| 4 | 拨码到 4(GND) |

2.4.3 AT_SW1 引脚设定(ATX/AT 模式设定)

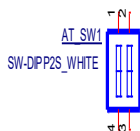

| 管脚 | ATX 模式 | AT 模式 |
|----|--------|-------|
| 1 | 拨码到 ON | 拨码到 1 |
| 2 | 拨码到 ON | 拨码到 2 |

2.4.4 COMe 220Pin 引脚定义

| Pin | Signal Name | Pin | Signal Name | Pin | Signal Name | Pin | Signal Name |
|-----|-------------|-----|-------------|-----|-----------------------|-----|------------------------|
| A1 | GND | B1 | GND | C1 | GND | D1 | GND |
| A2 | MDI3-_LAN2 | B2 | ACTIVITY_N2 | C2 | GND | D2 | GND |
| A3 | MDI3+_LAN2 | B3 | LPC_FRAME_N | C3 | USB31_P1_RX N | D3 | USB31_P1_C_T XN |
| A4 | LINK100_N2 | B4 | LPC_AD0 | C4 | USB31_P1_RX P | D4 | USB31_P1_C_T XP |
| A5 | LINK1000_N2 | B5 | LPC_AD1 | C5 | GND | D5 | GND |
| A6 | MDI2-_LAN2 | B6 | LPC_AD2 | C6 | USB32_P2_RX N | D6 | USB32_P2_TX N |
| A7 | MDI2+_LAN2 | B7 | LPC_AD3 | C7 | USB32_P2_RX P | D7 | USB32_P2_TXP |
| A8 | NC | B8 | NC | C8 | GND | D8 | GND |
| A9 | MDI1-_LAN2 | B9 | NC | C9 | NC | D9 | NC |
| A10 | MDI1+_LAN2 | B10 | LPC_CLK | C10 | NC | D10 | NC |
| A11 | GND | B11 | GND | C11 | GND | D11 | GND |
| A12 | MDI0-_LAN2 | B12 | PANSWH# | C12 | NC | D12 | NC |
| A13 | MDI0+_LAN2 | B13 | SMB_CLK | C13 | NC | D13 | NC |
| A14 | NC | B14 | SMB_DATA | C14 | GND | D14 | GND |
| A15 | SLP_S3_N | B15 | SMBALERT | C15 | NC | D15 | DDPB_CTRLCL K_AUX+ |
| A16 | SATA0_TXP | B16 | SATA1_TXP | C16 | NC | D16 | DDPB_CTRLDA TA_AUX- |
| A17 | SATA0_TXN | B17 | SATA1_TXN | C17 | NC | D17 | NC |
| A18 | SLP_S4_N | B18 | NC | C18 | NC | D18 | NC |
| A19 | SATA0_RXP | B19 | SATA1_RXP | C19 | PEG4_RXP7 | D19 | PEG4_TXP7 |
| A20 | SATA0_RXN | B20 | SATA1_RXN | C20 | PEG4_RXN7 | D20 | PEG4_TXN7 |
| A21 | GND | B21 | GND | C21 | GND | D21 | GND |
| A22 | SATA2_TXP | B22 | SATA3_TXP | C22 | PEG4_RXP8 | D22 | PEG4_TXP8 |
| A23 | SATA2_TXN | B23 | SATA3_TXN | C23 | PEG4_RXN8 | D23 | PEG4_TXN8 |
| A24 | SLP_S5_N | B24 | ATXPG | C24 | DDP1_HPD | D24 | NC |
| A25 | SATA2_RXP | B25 | SATA3_RXP | C25 | NC | D25 | NC |
| A26 | SATA2_RXN | B26 | SATA3_RXN | C26 | NC | D26 | DDI1_TXP0 |
| A27 | NC | B27 | WDTO_N | C27 | NC | D27 | DDI1_TXN0 |
| A28 | SATA_LED | B28 | NC | C28 | GND | D28 | NC |
| A29 | HDA_SYNC | B29 | NC | C29 | NC | D29 | DDI1_TXP1 |
| A30 | HDA_RST- | B30 | HDA_SDIN0 | C30 | NC | D30 | DDI1_TXN1 |
| A31 | GND | B31 | GND | C31 | GND | D31 | GND |
| A32 | HDA_BIT_CLK | B32 | SPK- | C32 | DDPC_CTRLCL K_AUX+ | D32 | DDI1_TXP2 |

| Pin | Signal Name | Pin | Signal Name | Pin | Signal Name | Pin | Signal Name |
|-----|------------------|-----|------------------|-----|------------------------|-----|----------------------|
| A33 | HDA_SDOUT | B33 | I2C1_SCL | C33 | DDPC_CTRLD ATA_AUX- | D33 | DDI1_TXN2 |
| A34 | NC | B34 | I2C1_SDA | C34 | DDPC_DDC_A UX_SEL | D34 | DDPB_DDC_AU X_SEL |
| A35 | THRMTRIP | B35 | CME_THRM | C35 | NC | D35 | NC |
| A36 | USB2_N7 | B36 | USB2_N8 | C36 | DDI3_AUXP | D36 | DDI1_TXP3 |
| A37 | USB2_P7 | B37 | USB2_P8 | C37 | DDI3_AUXN | D37 | DDI1_TXN3 |
| A38 | NC | B38 | NC | C38 | NC | D38 | NC |
| A39 | USB2_N5 | B39 | USB2_N6 | C39 | DDI3_TXP0 | D39 | DDI2_TXP0 |
| A40 | USB2_P5 | B40 | USB2_P6 | C40 | DDI3_TXN0 | D40 | DDI2_TXN0 |
| A41 | GND | B41 | GND | C41 | GND | D41 | GND |
| A42 | USB2_N3 | B42 | USB2_N4 | C42 | DDI3_TXP1 | D42 | DDI2_TXP1 |
| A43 | USB2_P3 | B43 | USB2_P4 | C43 | DDI3_TXN1 | D43 | DDI2_TXN1 |
| A44 | NC | B44 | USB_OC0_N | C44 | DDI3_HPD | D44 | DDI2_HPD |
| A45 | USB2_N1 | B45 | USB2_N2 | C45 | NC | D45 | NC |
| A46 | USB2_P1 | B46 | USB2_P2 | C46 | DDI3_TXP2 | D46 | DDI2_TXP2 |
| A47 | VCC_RTC | B47 | PLTRST_N2 | C47 | DDI3_TXN2 | D47 | DDI2_TXN2 |
| A48 | PLTRST_N2 | B48 | EXCD1_CPPE_ N | C48 | NC | D48 | NC |
| A49 | EXCD0_CPPE_ N | B49 | RST_N | C49 | DDI3_TXP3 | D49 | DDI2_TXP3 |
| A50 | SERIRQ | B50 | PLTRST_N2 | C50 | DDI3_TXN3 | D50 | DDI2_TXN3 |
| A51 | GND | B51 | GND | C51 | GND | D51 | GND |
| A52 | PEG4_TXP6 | B52 | PEG4_RXP6 | C52 | PEG4_RXP0 | D52 | PEG4_TXP0 |
| A53 | PEG4_TXN6 | B53 | PEG4_RXN6 | C53 | PEG4_RXN0 | D53 | PEG4_TXN0 |
| A54 | GP_D17 | B54 | GP_D6 | C54 | GND | D54 | NC |
| A55 | PEG4_TXP5 | B55 | PEG4_RXP5 | C55 | PEG4_RXP1 | D55 | PEG4_TXP1 |
| A56 | PEG4_TXN5 | B56 | PEG4_RXN5 | C56 | PEG4_RXN1 | D56 | PEG4_TXN1 |
| A57 | GND | B57 | GP_D5 | C57 | NC | D57 | NC |
| A58 | PEG4_TXP4 | B58 | PEG4_RXP4 | C58 | PEG4_RXP2 | D58 | PEG4_TXP2 |
| A59 | PEG4_TXN4 | B59 | PEG4_RXN4 | C59 | PEG4_RXN2 | D59 | PEG4_TXN2 |
| A60 | GND | B60 | GND | C60 | GND | D60 | GND |
| A61 | PEG4_TXP3 | B61 | PEG4_RXP3 | C61 | PEG4_RXP3 | D61 | PEG4_TXP3 |
| A62 | PEG4_TXN3 | B62 | PEG4_RXN3 | C62 | PEG4_RXN3 | D62 | PEG4_TXN3 |
| A63 | GP_D18 | B63 | GP_D8 | C63 | NC | D63 | NC |
| A64 | PEG4_TXP2 | B64 | PEG4_RXP2 | C64 | NC | D64 | SIO_RSMRST# |
| A65 | PEG4_TXN2 | B65 | PEG4_RXN2 | C65 | PEG4_RXP4 | D65 | PEG4_TXP4 |
| A66 | GND | B66 | WAKE_N | C66 | PEG4_RXN4 | D66 | PEG4_TXN4 |
| A67 | GP_D19 | B67 | NC | C67 | NC | D67 | GND |
| A68 | PEG4_TXP1 | B68 | PEG4_RXP1 | C68 | PEG4_RXP5 | D68 | PEG4_TXP5 |
| A69 | PEG4_TXN1 | B69 | PEG4_RXN1 | C69 | PEG4_RXN5 | D69 | PEG4_TXN5 |

| Pin | Signal Name | Pin | Signal Name | Pin | Signal Name | Pin | Signal Name |
|------|----------------|------|----------------|------|-------------|------|-------------|
| A70 | GND | B70 | GND | C70 | GND | D70 | GND |
| A71 | LVDS_TX_L2P | B71 | LVDS_TX_U0P | C71 | PEG4_RXP6 | D71 | PEG4_TXP6 |
| A72 | LVDS_TX_L2N | B72 | LVDS_TX_U0N | C72 | PEG4_RXN6 | D72 | PEG4_TXN6 |
| A73 | LVDS_TX_L1P | B73 | LVDS_TX_U1P | C73 | GND | D73 | GND |
| A74 | LVDS_TX_L1N | B74 | LVDS_TX_U1N | C74 | PEG4_RXP7 | D74 | PEG4_TXP7 |
| A75 | LVDS_TX_L0P | B75 | LVDS_TX_U2P | C75 | PEG4_RXN7 | D75 | PEG4_TXN7 |
| A76 | LVDS_TX_L0N | B76 | LVDS_TX_U2N | C76 | GND | D76 | GND |
| A77 | EDP_VDDEN_R | B77 | LVDS_TX_U3P | C77 | NC | D77 | ATX_PSON_N |
| A78 | LVDS_TX_L3P | B78 | LVDS_TX_U3N | C78 | PEG4_RXP8 | D78 | PEG4_TXP8 |
| A79 | LVDS_TX_L3N | B79 | EDP_BKEN_R | C79 | PEG4_RXN8 | D79 | PEG4_TXN8 |
| A80 | GND | B80 | GND | C80 | GND | D80 | GND |
| A81 | LVDS_TX_CLKL_P | B81 | LVDS_TX_CLK_UP | C81 | PEG4_RXP9 | D81 | PEG4_TXP9 |
| A82 | LVDS_TX_CLKL_N | B82 | LVDS_TX_CLK_UN | C82 | PEG4_RXN9 | D82 | PEG4_TXN9 |
| A83 | EDP_AUX_C_P | B83 | EDP_BKCTL_R | C83 | NC | D83 | SIO_PWROK |
| A84 | EDP_AUX_C_N | B84 | 5VSB_ATX | C84 | GND | D84 | GND |
| A85 | GP_D20 | B85 | 5VSB_ATX | C85 | PEG4_RXP10 | D85 | PEG4_TXP10 |
| A86 | NC | B86 | 5VSB_ATX | C86 | PEG4_RXN10 | D86 | PEG4_TXN10 |
| A87 | EDP_HPD | B87 | 5VSB_ATX | C87 | GND | D87 | GND |
| A88 | CLK_SRC2_DP | B88 | NC | C88 | PEG4_RXP11 | D88 | PEG4_TXP11 |
| A89 | CLK_SRC2_DN | B89 | MONRED | C89 | PEG4_RXN11 | D89 | PEG4_TXN11 |
| A90 | GND | B90 | GND | C90 | GND | D90 | GND |
| A91 | V1P8A | B91 | MONGREEN | C91 | PEG4_RXP12 | D91 | PEG4_TXP12 |
| A92 | SPI0_MISO_IO_1 | B92 | MONBLUE | C92 | PEG4_RXN12 | D92 | PEG4_TXN12 |
| A93 | GP_D5 | B93 | MONHSYNC | C93 | GND | D93 | GND |
| A94 | SPI0_CLK | B94 | MONVSYNC | C94 | PEG4_RXP13 | D94 | PEG4_TXP13 |
| A95 | SPI0_MOSI_IO_0 | B95 | VGA_SCL | C95 | PEG4_RXN13 | D95 | PEG4_TXN13 |
| A96 | TPM_PP | B96 | VGA_SDA | C96 | GND | D96 | GND |
| A97 | NC | B97 | SPI0_CS0_N | C97 | NC | D97 | NC |
| A98 | SOUT3 | B98 | NC | C98 | PEG4_RXP14 | D98 | PEG4_TXP14 |
| A99 | SIN3 | B99 | NC | C99 | PEG4_RXN14 | D99 | PEG4_TXN14 |
| A100 | GND | B100 | GND | C100 | GND | D100 | GND |
| A101 | SOUT4 | B101 | SYSFANOUT | C101 | PEG4_RXP15 | D101 | PEG4_TXP15 |
| A102 | SIN4 | B102 | SYSFANIN | C102 | PEG4_RXN15 | D102 | PEG4_TXN15 |
| A103 | PCH_GPIO4 | B103 | CME_SLEEP_N | C103 | GND | D103 | GND |
| A104 | DC12 | B104 | DC12 | C104 | DC12 | D104 | DC12 |
| A105 | DC12 | B105 | DC12 | C105 | DC12 | D105 | DC12 |
| A106 | DC12 | B106 | DC12 | C106 | DC12 | D106 | DC12 |

| Pin | Signal Name | Pin | Signal Name | Pin | Signal Name | Pin | Signal Name |
|------|-------------|------|-------------|------|-------------|------|-------------|
| A107 | DC12 | B107 | DC12 | C107 | DC12 | D107 | DC12 |
| A108 | DC12 | B108 | DC12 | C108 | DC12 | D108 | DC12 |
| A109 | DC12 | B109 | DC12 | C109 | DC12 | D109 | DC12 |
| A110 | GND | B110 | GND | C110 | GND | D110 | GND |

第三章 BIOS 程序设置

AMI BIOS 刷新

BIOS 提供对硬件资源的底层驱动，是联系硬件和操作系统的桥梁。现在硬件和各种应用软件不断更新，当您的系统遇到问题时，例如系统不支持最新公布的 CPU 时，就需要升级您的 BIOS 了。

注意：

1. 升级 BIOS 只在遇到问题，必要的时候进行。
2. 在升级过程中不要关闭电源或重新启动系统，以免造成您的 BIOS 资料将被损坏，系统也可能不能启动。
3. 为防止意外发生，请您先备份当前的 BIOS 资料。

AMI BIOS 描述

开机时，BIOS 会对主板上的硬件进行自我诊断，设定硬件时序参数等工作，最后才将系统控制权交给操作系统。如何正确的设定 BIOS 参数对系统是否稳定的工作及系统是否工作在最佳状态至关重要。

进入 BIOS 参数设置

电脑开机，在完成自我诊断后，屏幕上会显示出如下信息：Del->SETUP，此时您点击一下 Del 键，则 BIOS 在完成 IDE 等设备的侦测后会自动转入 SETUP 设置画面。

1. 打开系统电源或重新启动系统，显示器屏幕将出现自我测试的信息。
2. 当屏幕中间出现“Pressto enter setup”提示时，按下键，就可以进入 BIOS 设定程序。
3. 以方向键移动至您要修改的选项，按下<Enter>键即可进入该选项的子画面。
4. 使用方向键及<Enter>键即可修改所选项目的值，按回车键选择 BIOS 选项并修改。
5. 任何时候按下<Esc>键即可回到上一画面。



提示：BIOS 参数属于系统关键信息，请勿随意设置，如需设置或者升级请联系我司售后支持，谢谢！

3.1 Main Screen

The Main screen is the first screen that is displayed when the BIOS Setup is entered.

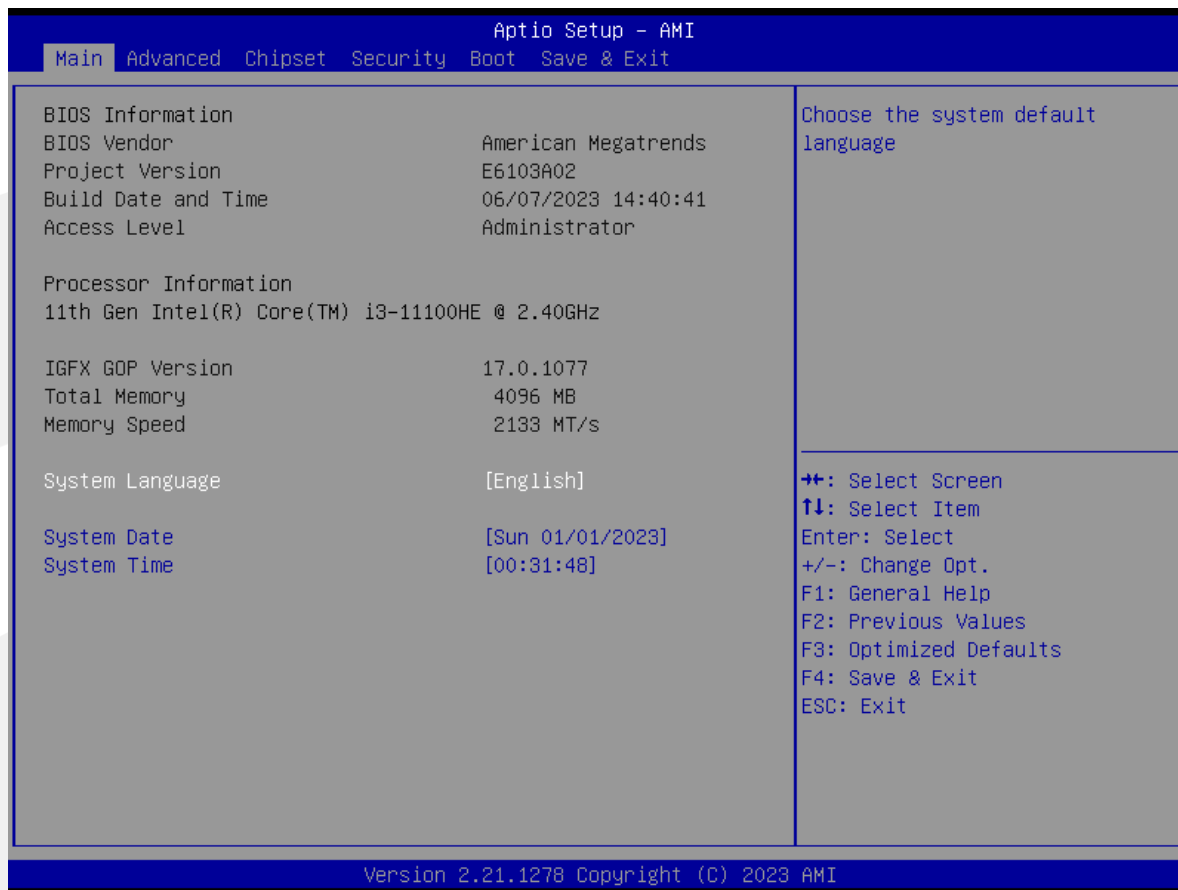

| Setup Item | Options | Help Text | Comments |
|-------------------------|---------|-----------|--|
| BIOS Information | | | |
| BIOS Vendor | | | Displays BIOS vendor. |
| Project Version | | | Displays the current BIOS version: Format: AAAABBC AAAAA = Project name BB = BIOS revision C = Customer number |
| Build Date and Time | | | Displays the current BIOS build date. |
| Access Level | | | Displays password level that setup is running in: Administrator or User. With no passwords set, Administrator is the default mode. |

| Setup Item | Options | Help Text | Comments |
|------------------------------|-----------------------------|-------------------------------------|--|
| Processor Information | | | |
| CPU XXXXX | | | Displays the CPU Brand String installed in the system. |
| Total Memory | | | Displays the total physical memory installed in the system, MB Unit. |
| Memory Speed | | | |
| System Language | English | Choose the system default language. | |
| System Date | [Day of week MM/DD/YYYY] | Set and display the Date. | |
| System Time | [HH:MM:SS] | Set and display the Time. | |

3.2 Advanced Screen

The Advanced screen provides an access point to configure several options. On this screen, the user selects the option that is to be configured.



| Setup Item | Options | Help Text | Comments |
|-----------------------------|---------|--|----------|
| CPU Configuration | | CPU Configuration Parameters. | |
| ACPI Settings | | System ACPI Parameters. | |
| Super IO Configuration | | System Super IO chip Parameters. | |
| Hardware Monitor | | Monitor hardware states. | |
| SATA Configuration | | SATA Devices Configuration. | |
| USB Configuration | | USB Configuration Parameters. | |
| Network Stack configuration | | Enable/Disable UEFI Network Stack. | |
| CSM Configuration | | CSM configuration: Enable/Disable, Option ROM execution settings, etc. | |
| Watchdog configuration | | Set System Watchdog Parameters. | |
| LVDS Panel | | LVDS Panel Settings. | |

3.2.1 CPU Configuration Screen

The CPU Configuration screen allows the user to view the processor information, and to enable or disable processor options. To access this screen from the Main screen, choose **Advanced > CPU Configuration**.

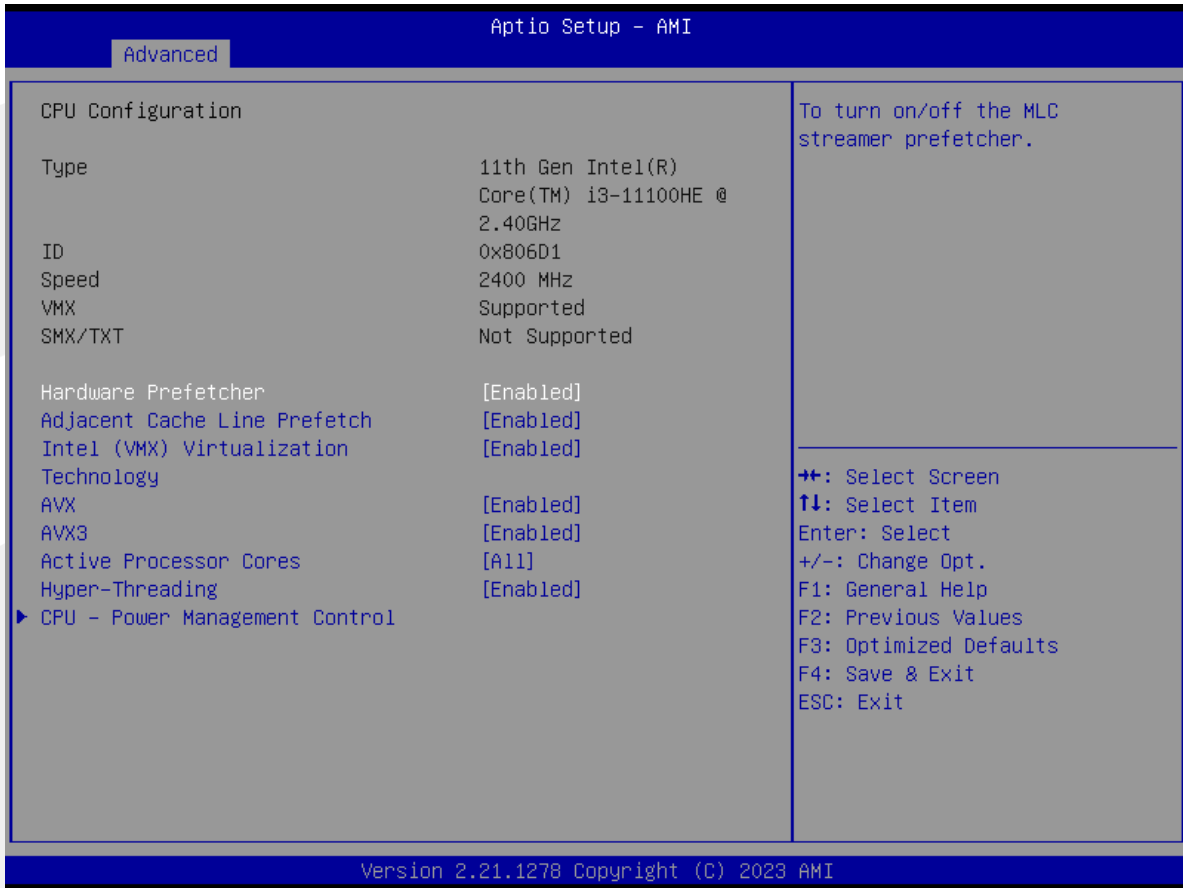

Aptio Setup - AMI

Advanced

| | |
|--|--|
| <p>CPU - Power Management Control</p> <p>Boot performance mode [Max Non-Turbo]</p> <p>Intel(R) SpeedStep(tm) [Enabled]</p> <p> Turbo Mode [Enabled]</p> <p>▶ Config TDP Configurations</p> <p> C states [Disabled]</p> | <p>Select the performance state that the BIOS will set starting from reset vector.</p> <hr/> <p> ++: Select Screen ↑↓: Select Item Enter: Select +/-: Change Opt. F1: General Help F2: Previous Values F3: Optimized Defaults F4: Save & Exit ESC: Exit </p> |
|--|--|

Version 2.21.1278 Copyright (C) 2023 AMI

Aptio Setup - AMI

Advanced

| | |
|--|---|
| <p>Config TDP Configurations</p> <p>Enable Configurable TDP [Applies to cTDP]</p> <p>Configurable TDP Boot Mode [Nominal]</p> <p>Configurable TDP Lock [Disabled]</p> <p>CTDP BIOS control [Disabled]</p> <p>ConfigTDP Levels 2</p> <p>ConfigTDP Turbo Activation Ratio 23 (Unlocked)</p> <p>Power Limit 1 45.0W (MSR:45.0)</p> <p>Power Limit 2 55.0W (MSR:55.0)</p> <p>Custom Settings Nominal</p> <p>ConfigTDP Nominal Ratio:24 TAR:23 PL1:13.0W</p> <p>Power Limit 1 0</p> <p>Power Limit 2 0</p> <p>Power Limit 1 Time Window [0]</p> <p>ConfigTDP Turbo Activation Ratio 0</p> <p>Custom Settings Down</p> <p>ConfigTDP Level1 Ratio:19 TAR:18 PL1:3.0W</p> <p>Power Limit 1 0</p> <p>Power Limit 2 0</p> <p>Power Limit 1 Time Window [0]</p> <p>ConfigTDP Turbo Activation Ratio 0</p> | <p>Applies TDP initialization settings based on non-cTDP or cTDP. Default is 1: Applies to cTDP; if 0 then applies non-cTDP and BIOS will bypass cTDP initialization flow</p> <hr/> <p> ++: Select Screen ↑↓: Select Item Enter: Select +/-: Change Opt. F1: General Help F2: Previous Values F3: Optimized Defaults F4: Save & Exit ESC: Exit </p> |
|--|---|

Version 2.21.1278 Copyright (C) 2023 AMI

| Setup Item | Options | Help Text | Comments |
|-------------------------------------|--|---|----------|
| CPU Configuration | | | |
| Type | | | |
| ID | | | |
| Speed | | | |
| VMX | | | |
| SMX/TXT | | | |
| Hardware Prefetcher | Enabled Disabled | To turn on/off the MLC streamer prefetcher. | |
| Adjacent Cache line Prefetch | Enabled Disabled | To turn on/off prefetching of adjacent cache lines. | |
| Intel(VMX) Technology | Enabled Disabled | When enabled, a VMM can utilize the additional hardware capabilities provided by Vanderpool technology. | |
| AVX | Enabled | | |
| AVX3 | Enabled | | |
| Active Processor Cores | All 1 2 3 | Number of cores to enable in each processor package. | |
| Hyper-Threading | Enabled | | |
| CPU Power Management Control | | | |
| Boot performance mode | Max Non-Turbo Max battery Turbo Performance | Select the performance state that the BIOS will set starting from reset vector. | |
| Intel® SpeedStep™ | Enabled Disabled | Allows more than two frequency ranges to be supported. | |
| Turbo Mode | Enabled | | |
| C states | Disabled | | |
| Config TDP configurations | | | |
| Enable Configurable TDP | Applies to cTDP | | |
| Configurable TDP Boot Mode | Nominal | | |
| Configurable TDP Lock | Disabled | | |
| CTDP BIOS control | Disabled | | |
| ConfigTDP Nominal | | | |
| Power Limit1 | 0 | | |
| Power Limit2 | 0 | | |

3.2.2 ACPI Settings Screen

The ACPI Settings screen allows the user to set the system ACPI parameters. To access this screen from the Main screen, choose **Advanced > ACPI Settings**.

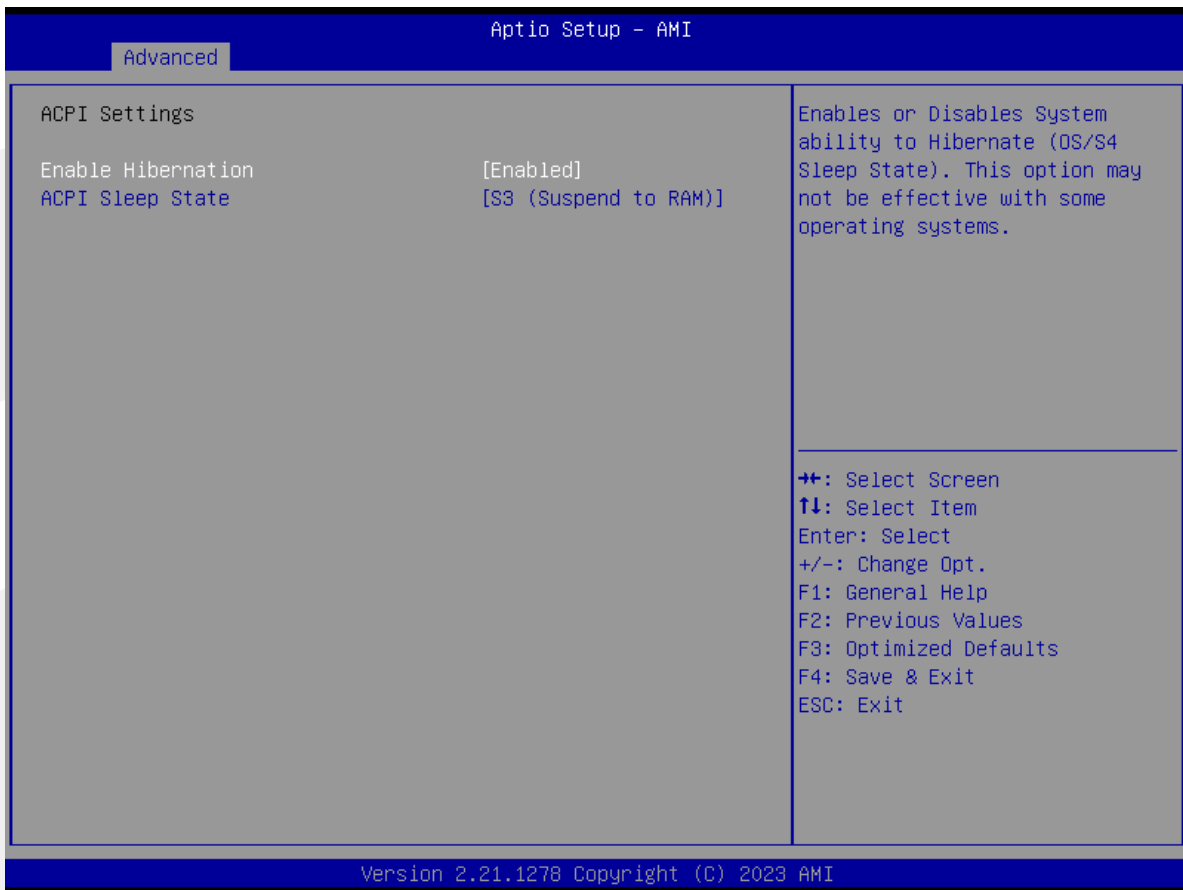

| Setup Item | Options | Help Text | Comments |
|----------------------|---|---|-----------------------------|
| ACPI Settings | | | |
| Enable Hibernation | Enabled | | |
| ACPI Sleep State | Suspend Disabled S3 (Suspend to RAM) | Select the highest ACPI sleep state the system will enter when the SUSPEND button is pressed. | Sleep supported optionally. |

3.2.3 Super IO Configuration

The Super IO Configuration screen allows the user to view the super IO information, and to enable or disable super IO options. To access this screen from the Advanced screen, choose **Advanced > Super IO Configuration**.



| Setup Item | Options | Help Text | Comments |
|-------------------------------|---------|-----------|---|
| Super IO Configuration | | | |
| Serial Port 1 Configuration | | | Set Parameters of Serial Port 1 (COM1). |
| Serial Port 2 Configuration | | | Set Parameters of Serial Port 2 (COM2). |

3.2.3.1 Serial PortX Configuration

The Super IO Configuration screen allows the user to view the super IO information, and to enable or disable serial port options. To access this screen from the Advanced screen, choose **Advanced->Super IO Configuration->Serial PortX Configuration**.

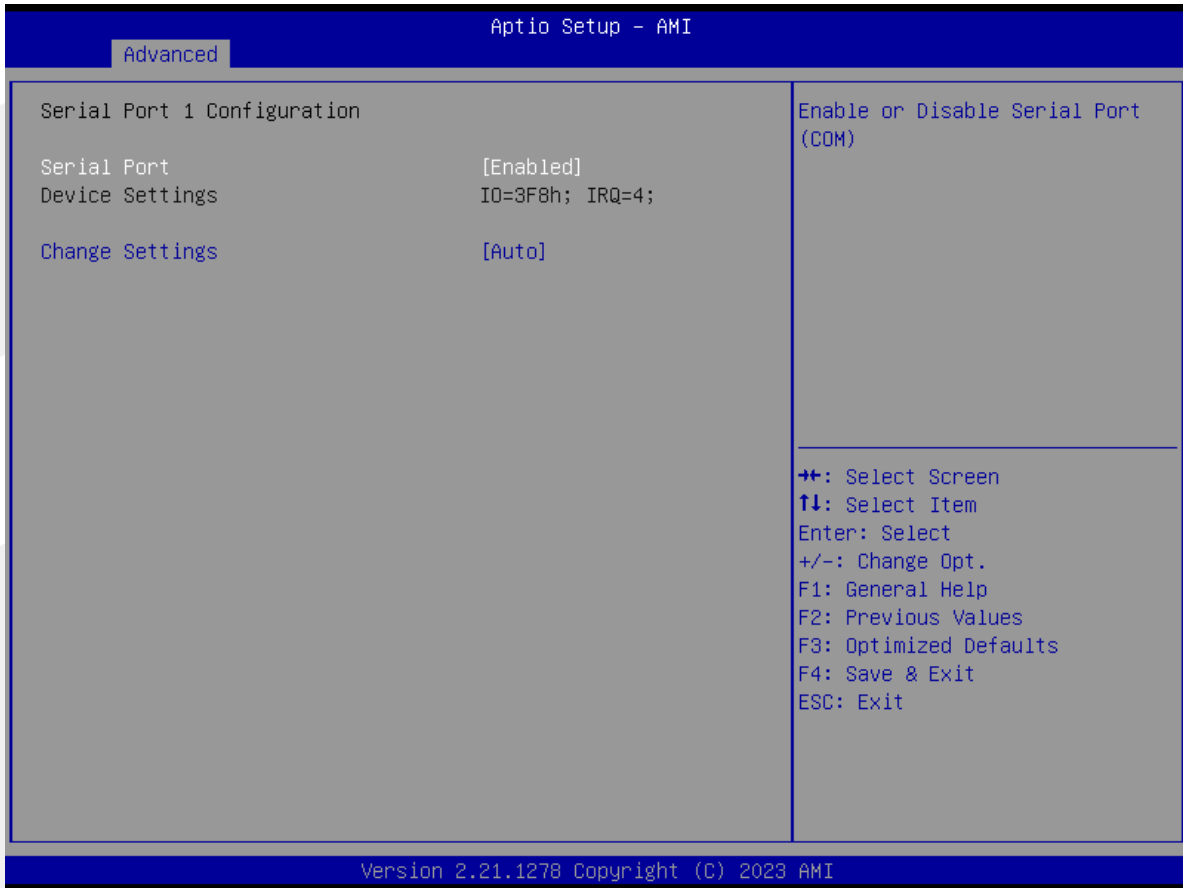

| Setup Item | Options | Help Text | Comments |
|-----------------------------------|--|---|----------|
| Serial PortX Configuration | | | |
| Serial Port | Enabled Disabled | Enable or Disable Serial Port (COM). | |
| Change Settings | Auto IO=3F8h; IRQ=4 IO=3F8h; IRQ=3,4,5,6,7,9,10,11,12 IO=2F8h; IRQ=3,4,5,6,7,9,10,11,12 IO=3E8h; IRQ=3,4,5,6,7,9,10,11,12 IO=2E8h; IRQ=3,4,5,6,7,9,10,11,12 | Select an optimal settings for Super IO Device. | |

3.2.4 Hardware Monitor

The hardware monitor screen allows the user to view the hardware information. To access this screen from the Advanced screen, choose **Advanced-> Hardware Monitor**.



| Setup Item | Options | Help Text | Comments |
|-------------------------|---|--------------------------------|---|
| PC Health Status | | | |
| CPU FAN Mode Setting | Full On mode Automatic mode Manual mode | Fan control mode select. | When Manual mode selected, Manual PWM Setting shows to set FAN PWM Duty. |
| SYS FAN Mode Setting | Full On mode Automatic mode Manual mode | Fan control mode select. | When Manual mode selected, Manual PWM Setting shows to set FAN PWM Duty. |
| Manual PWM | 255 | | |
| CPU temperature | | Shows Current CPU temperature. | NOTE1: Sometimes not the actual temperature value, just indicates temperature tolerance limitation. |
| Fan2 Speed | | | HW Information. |

3.2.5 SATA Configuration

The SATA Configuration screen allows the user to view the SATA Controller information, and to enable or disable SATA Controller options. To access this screen from the Main screen, choose **Advanced > SATA Configuration**.

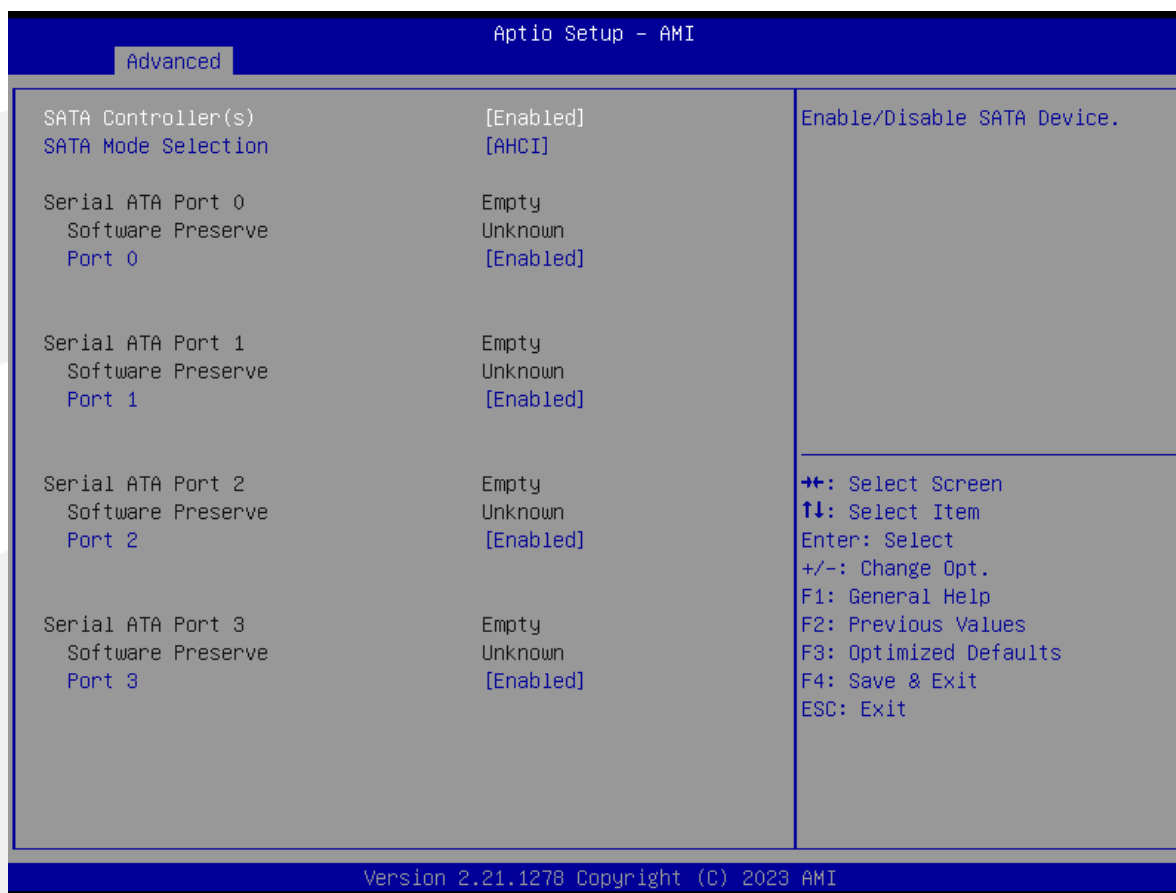

| Setup Item | Options | Help Text | Comments |
|---------------------------|---------------------|-----------------------------|---------------------------------|
| SATA Configuration | | | |
| SATA Configuration | | | |
| SATA Controller(s) | Enabled Disabled | Enable/Disable SATA Device. | |
| SATA Mode Selection | AHCI Mode | Select AHCI. | |
| Serial ATA Port 0 | | | Show HDD information connected. |
| Serial ATA Port 1 | | | |
| Serial ATA Port 2 | | | |
| Serial ATA Port 3 | | | |

Note: If SATA or PCIe RAID groups are configured separately, contact technical support.

3.2.6 USB Configuration

The USB Configuration screen allows the user to view the USB Configuration information, and to enable or disable options. To access this screen from the Main screen, choose **Advanced > USB Configuration**.

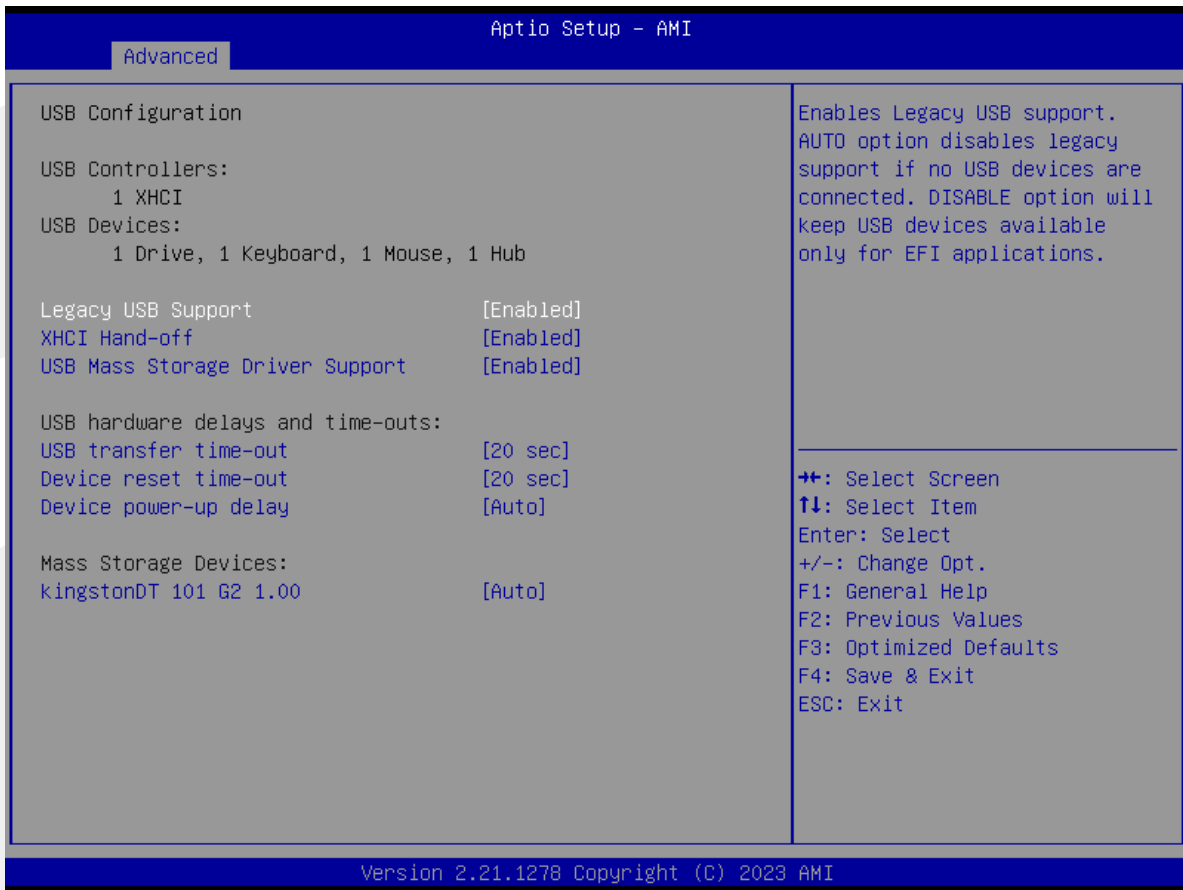

| Setup Item | Options | Help Text | Comments |
|--|------------------------------------|--|----------|
| USB Configuration | | | |
| Legacy USB Support | Enabled Disabled | Enables Legacy USB support. AUTO option disables legacy support if no USB devices are connected. DISABLE option will keep USB devices available only for EFI applications. | |
| XHCI Hand-off | Enabled Disabled | This is a workaround for OSes without XHCI hand-off support. The XHCI ownership change should be claimed by XHCI driver. | |
| USB MASS Storage Driver Support | Enabled Disabled | Enable/Disable USB Mass Storage Driver Support. | |
| USB hardware delays and time-outs | | | |
| USB transfer time-out | 1 sec 5 sec 10 sec 20 sec | The time-out value for Control, Bulk, and Interrupt transfers. | |
| Device reset time-out | 1 sec 5 sec 10 sec 20 sec | USB mass storage device Start Unit command time-out. | |
| Device power-up delay | Auto Manual | Maximum time the device will take before it properly reports itself to the Host Controller. ' auto' uses default value: for a Root port it is 100ms,for a Hub port the delay is taken from Hub descriptor. | |
| Mass Storage Device | | | |
| kingstonDT 101 G2 1.00 | Auto | | |

3.2.7 Network Stack Configuration

To access this screen from the Main screen, choose **Advanced > Network Stack Configuration**.



| Setup Item | Options | Help Text | Comments |
|------------------------------------|---------------------|-----------|--|
| Network Stack Configuration | | | |
| Network Stack | Disabled Enabled | | Enable/Disable UEFI Network Stack. |
| IPv4 PXE Support | Disabled Enabled | | Enable/Disable IPv4 PXE boot support. |
| IPv4 HTTP Support | Disabled Enabled | | Enable/Disable IPv4 HTTP boot support. |
| IPv6 PXE Support | Disabled Enabled | | Enable/Disable IPv6 PXE boot support. |
| IPv6 HTTP Support | Disabled Enabled | | Enable/Disable IPv6 HTTP boot support. |

3.2.8 CSM Configuration

The CSM Configuration screen allows the user to view the CSM information, and to enable or disable CSM options. To access this screen from the Main screen, choose **Advanced > CSM Configuration**.

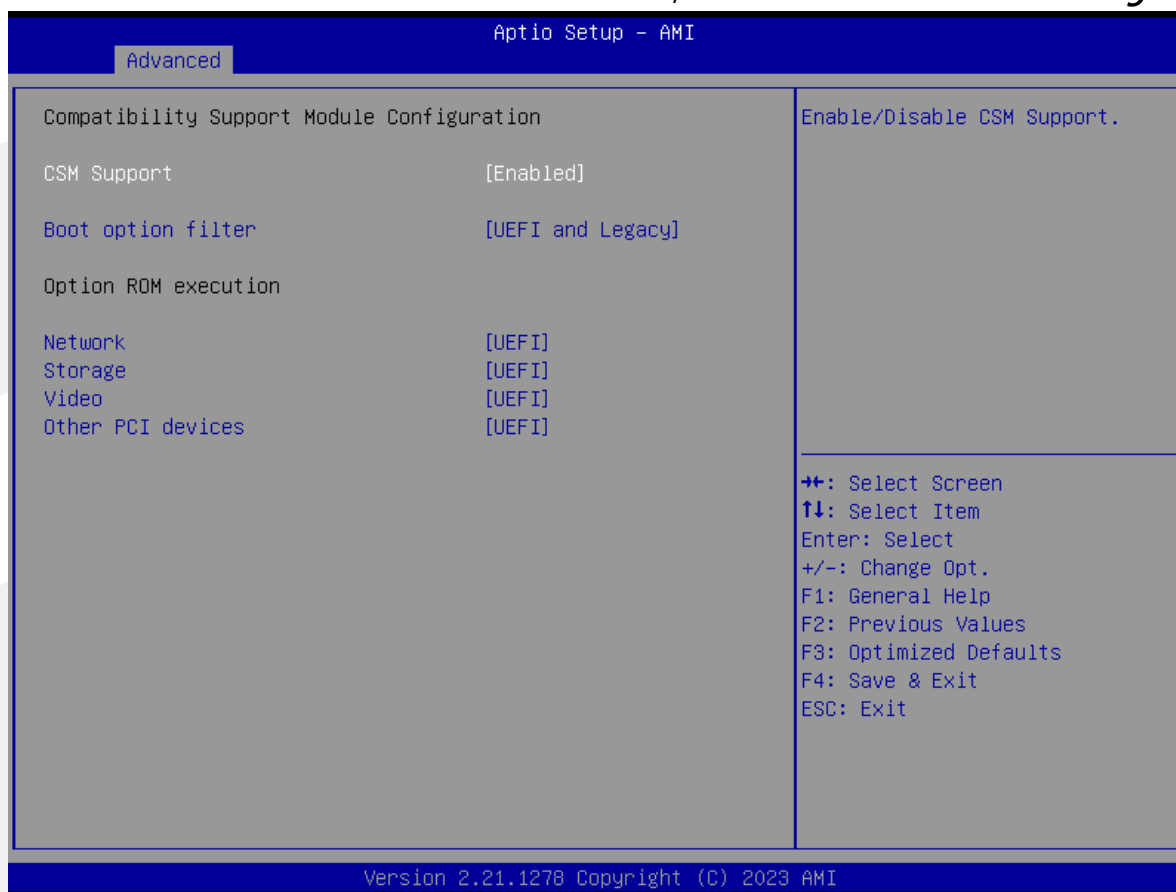

| Setup Item | Options | Help Text | Comments |
|--------------------------|---|--|----------|
| CSM Configuration | | | |
| CSM Support | Enabled Disabled | Enable/Disable CSM support. | |
| Boot option filter | UEFI and Legacy Legacy only UEFI only | This option control Legacy/UEFI ROMs priority. | |
| Network | Legacy UEFI Do not lunch | Control the execution of UEFI and Legacy PXE OpROM. | |
| Storage | Legacy UEFI Do not lunch | Control the execution of UEFI and Legacy Storage OpROM. | |
| Video | Legacy UEFI Do not lunch | Control the execution of UEFI and Legacy video OpROM. | |
| Other PCI devices | Legacy UEFI Do not lunch | Determines OpROM execution policy for devices other than Network,Storage or video. | |

3.2.9 Watchdog Configuration

The Watchdog Configuration screen allows the user to Set System WatchDog Parameters. To access this screen from the Main screen, choose **Advanced > Watchdog Configuration**.



| Setup Item | Options | Help Text | Comments |
|-------------------------------|---------------------|-----------|--|
| Watchdog Configuration | | | |
| WatchDog Control | Disabled Enabled | | WatchDog function. |
| WatchDog Count Mode | Minute Second | | WatchDog Count Mode Selection. |
| WatchDog TimeOut Value | 1 | | Fill WatchDog TimeOut (0~255),0 means function disabled. |

3.2.10 LVDS Panel

To access this screen from the Main screen, choose **Advanced > LVDS Panel**.

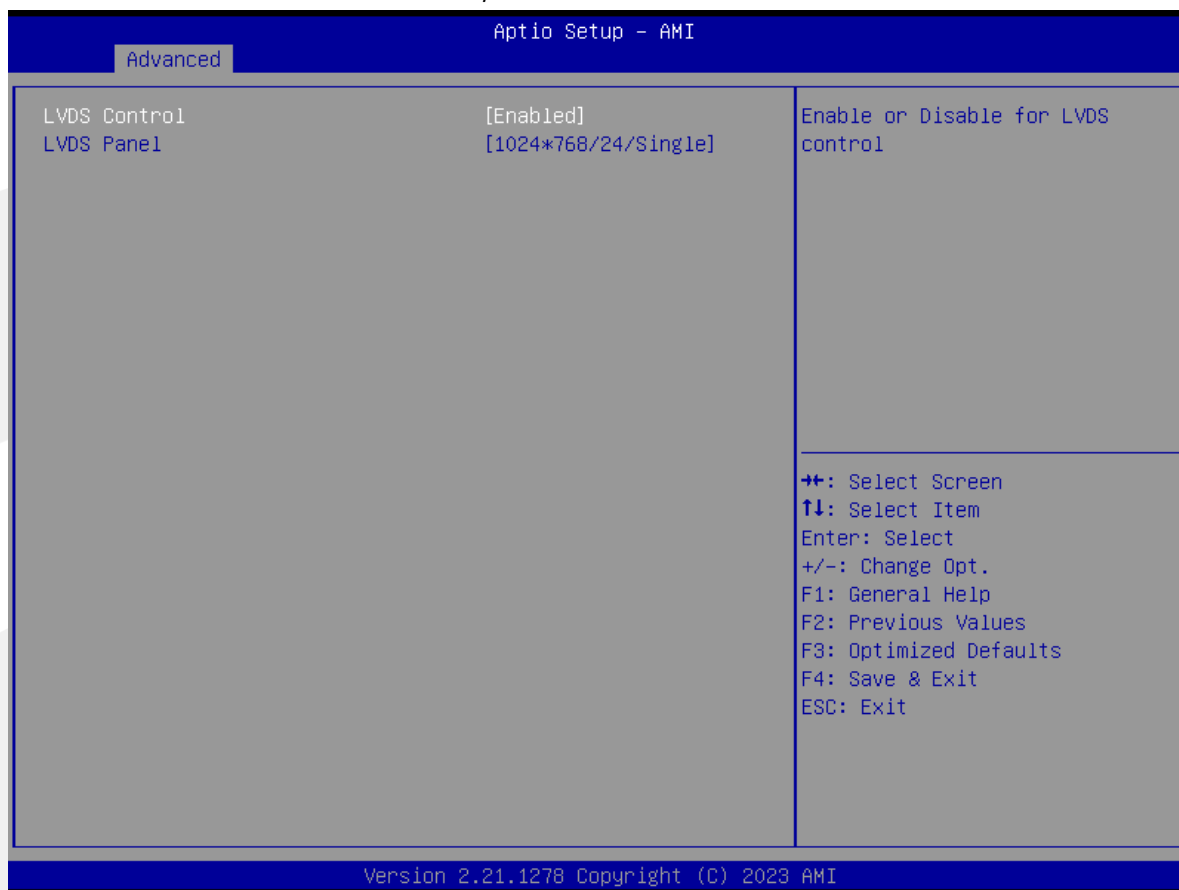

| Setup Item | Options | Help Text | Comments |
|-------------------|---------------------|-----------|-------------------------------------|
| LVDS Panel | | | |
| LVDS Control | Disabled Enabled | | Enable or Disable for LVDS control. |
| LVDS Panel | 1024*768/24/Single | | |

3.3 Chipset Screen

The Chipset screen provides an access point to configure SA Configuration and PCH-IO configuration. To access this screen from the Main screen, press the right arrow until the Chipset screen is chosen.



| Setup Item | Options | Help Text | Comments |
|---------------------------------|---------|-------------------------------|----------|
| Chipset Screen | | | |
| System Agent (SA) Configuration | | System Agent (SA) Parameters. | |
| PCH-IO Configuration | | PCH Parameters. | |

3.3.1 System Agent (SA) Configuration

The North Bridge Screen allows user to set NB chipset configuration. To access this screen, from the Main screen, choose **Chipset> System Agent (SA) Configuration**.

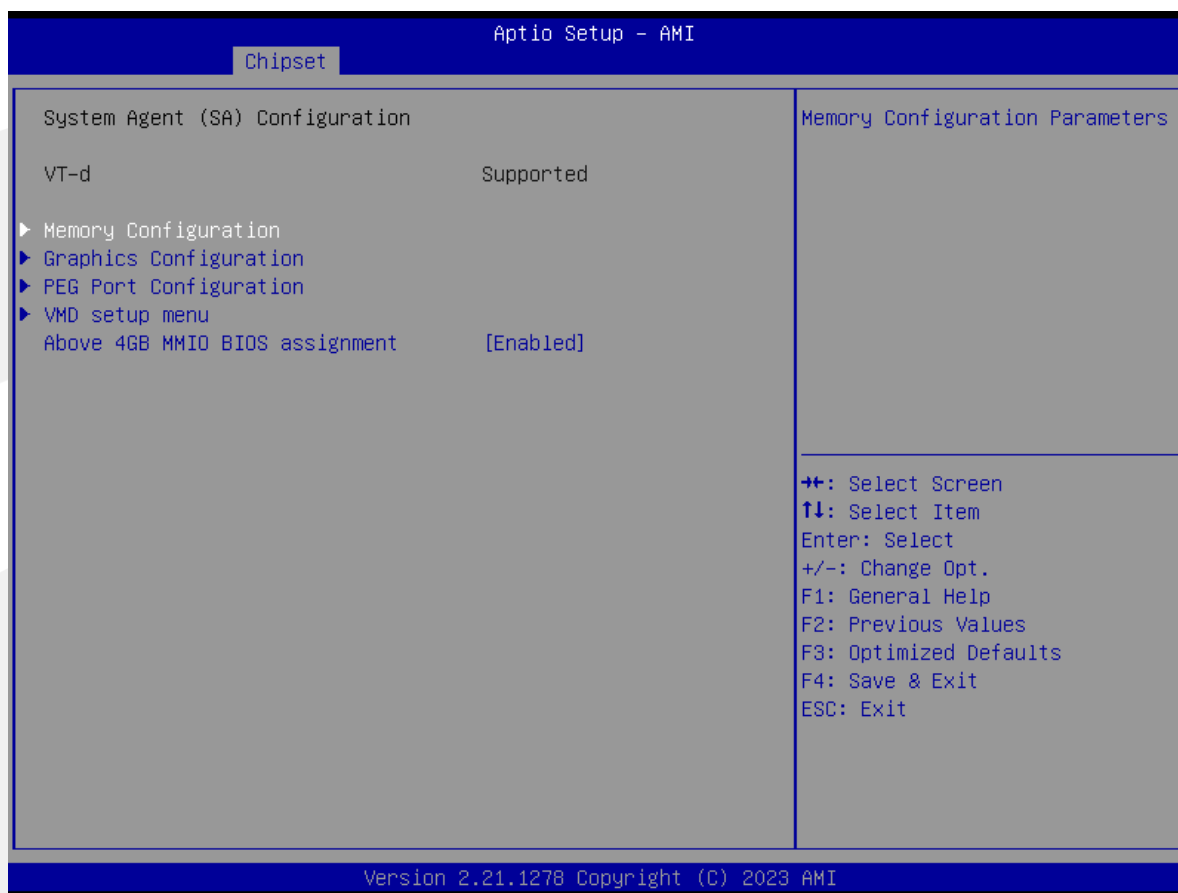

Aptio Setup - AMI

Chipset

| | | |
|------------------------------------|---------------------------------------|--|
| Memory Configuration | | Maximum Memory Frequency Selections in Mhz. |
| Memory RC Version | 2.0.2.2 | |
| Memory Speed | 2133 MT/s | ++: Select Screen ↑↓: Select Item Enter: Select +/-: Change Opt. F1: General Help F2: Previous Values F3: Optimized Defaults F4: Save & Exit ESC: Exit |
| Memory Timings (tCL-tRCD-tRP-tRAS) | 15-15-15-35 | |
| Controller 0 Channel 0 Slot 0 Size | Populated & Enabled 4096 MB (DDR4) | |
| Controller 0 Channel 0 Slot 1 | Not Populated / Disabled | |
| Controller 1 Channel 0 Slot 0 | Not Populated / Disabled | |
| Controller 1 Channel 0 Slot 1 | Not Populated / Disabled | |
| Maximum Memory Frequency | [Auto] | |

Version 2.21.1278 Copyright (C) 2023 AMI

Aptio Setup - AMI

Chipset

| | | |
|------------------------|---------|--|
| Graphics Configuration | | Select which of IGFX/PEG/PCI Graphics device should be Primary Display Or select HG for Hybrid Gfx. |
| Primary Display | [Auto] | |
| Select PCIE Card | [Auto] | ++: Select Screen ↑↓: Select Item Enter: Select +/-: Change Opt. F1: General Help F2: Previous Values F3: Optimized Defaults F4: Save & Exit ESC: Exit |
| Internal Graphics | [Auto] | |
| GTT Size | [8MB] | |
| Aperture Size | [256MB] | |
| DVMT Pre-Allocated | [60M] | |
| DVMT Total Gfx Mem | [256M] | |
| ▶ LCD Control | | |

Version 2.21.1278 Copyright (C) 2023 AMI

| Setup Item | Options | Help Text | Comments |
|--|---|--|----------|
| System Agent (SA) Configuration | | | |
| Memory Configuration | | | |
| Memory Information | | Show Memory information. | |
| Graphics Configuration | | | |
| Primary Display | Auto IGFX PEG PCH | Select which of IGFX/PEG/PCI Graphics device should be Primary Display Or select HG for Hybrid Gfx. | |
| Internal Graphics | Auto Disabled Enabled | Keep IGFX enabled based on the setup options. | |
| GTT Size | 2MB 4MB 8MB | Select the GTT Size. | |
| Aperture Size | 128MB 256MB 512MB 1024MB 2048MB | Select the Aperture Size. Note: Above 4GB MMIO BIOS assignment is automatically enabled when selecting 2048MB aperture. To use this feature, please disable CSM Support. | |
| DVMT Total Gfx Mem | 128M 256M MAX | Select DVMT5.0 Total Graphic Memory size used by the Internal Graphics Device. | |

3.3.2 PCH-IO Configuration

The South Bridge Screen allows user to set SB chipset configuration. To access this screen form the Main screen, choose **Chipset> PCH-IO Configuration**.

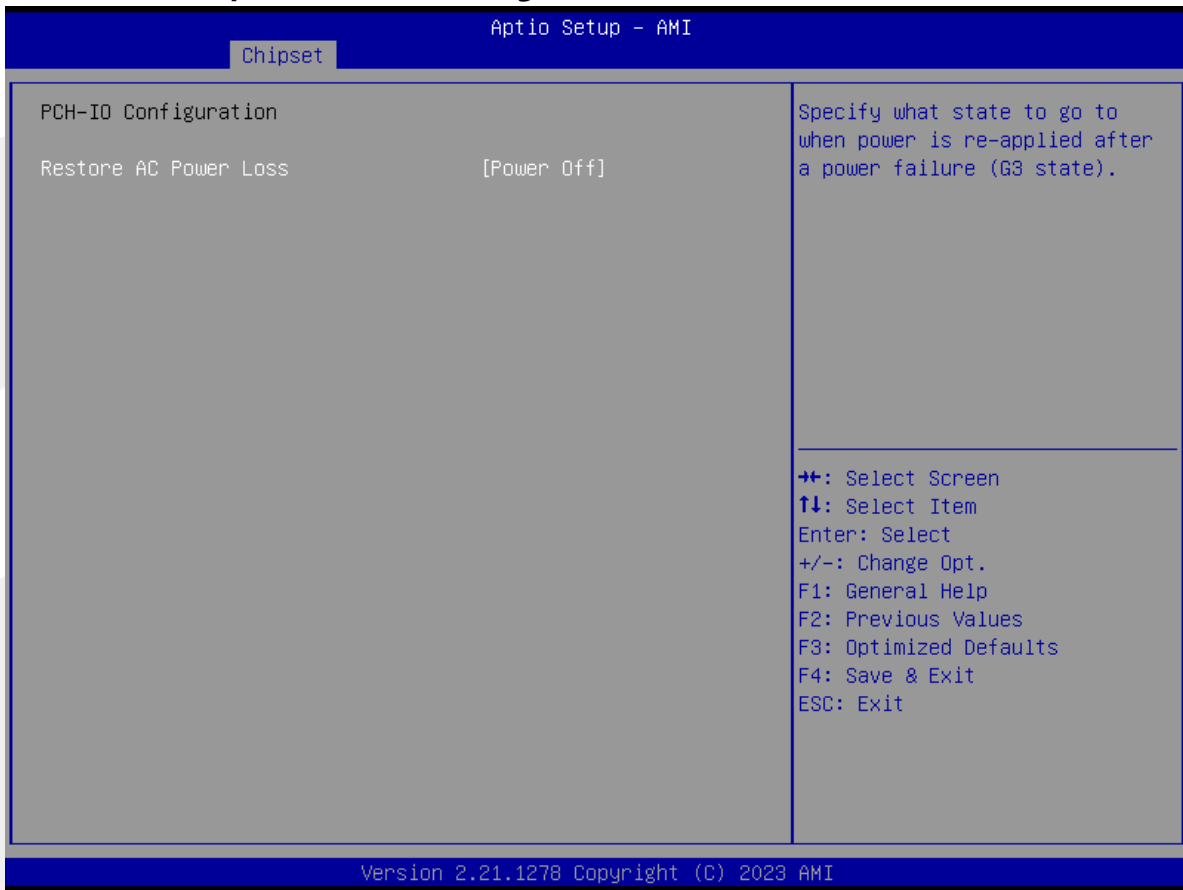

| Setup Item | Options | Help Text | Comments |
|-----------------------------|-----------------------|---|----------|
| PCH-IO Configuration | | | |
| Restore AC Power Loss | Power on Power off | Select AC power state when power is re-applied after a power failure. | |

3.4 Security

To access this screen form the Main screen, choose **Security**.



| Setup Item | Options | Help Text | Comments |
|------------------------|---------|-----------------------------|----------|
| Security | | | |
| Administrator Password | | Set Administrator Password. | |
| User Password | | Set User Password. | |

3.5 Boot Screen

The Boot screen displays any bootable media encountered during POST, and allows the user to configure desired boot device. To access this screen from the Main screen, choose **Boot**

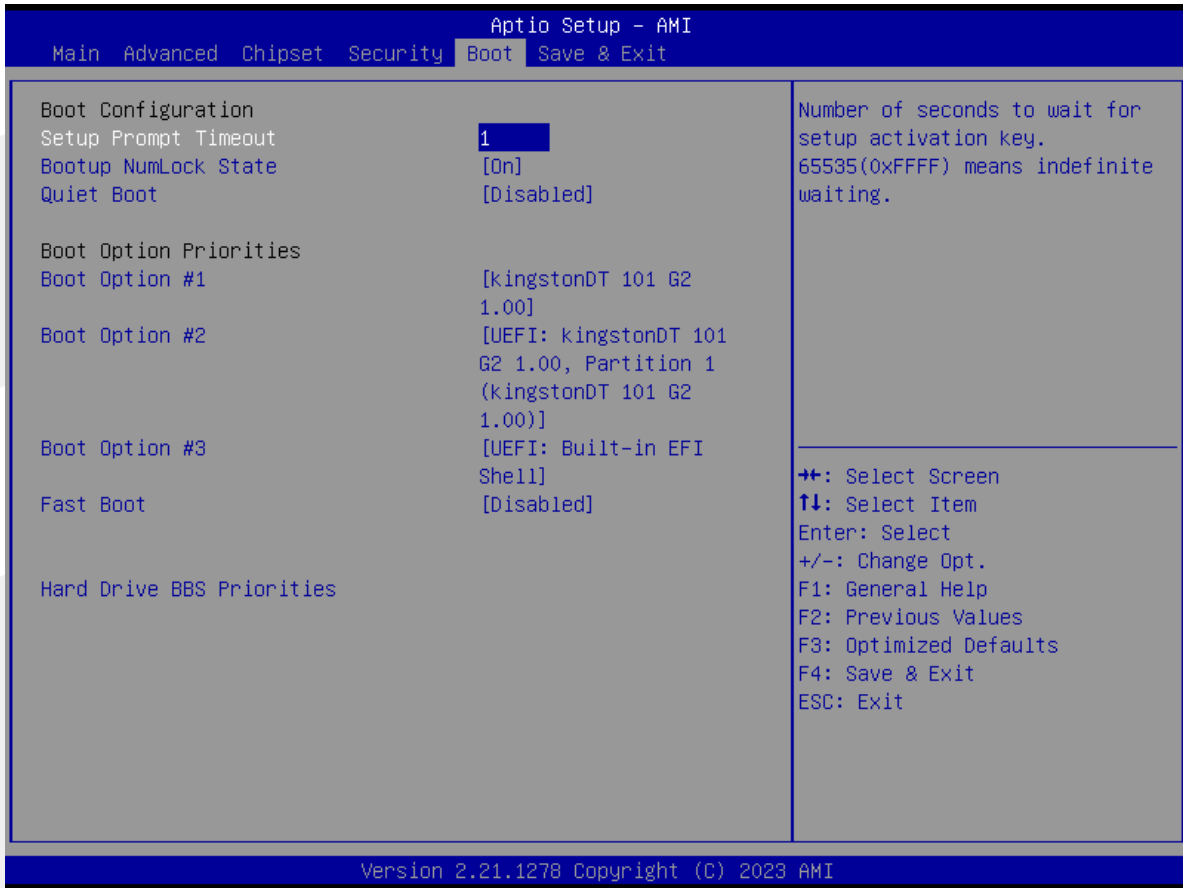

| Setup Item | Options | Help Text | Comments |
|-------------------------------|---------------------|--|---|
| Boot Configuration | | | |
| Setup Prompt Timeout | 1~65535 | Number of seconds to wait for setup activation key.65535(0xFFFF) means indefinite waiting. | Setup Prompt Timeout. |
| Bootup NumLock State | On off | Select the keyboard Number state. | Bootup NumLock State. |
| Quiet Boot | Disabled Enabled | Enables or disables Quiet Boot option. | Quiet Boot. |
| Boot Option Priorities | | | |
| Boot Option #1 | | Sets the system boot order. | Note: Showed When boot devices existed. |
| Boot Option #2 | | Sets the system boot order. | |
| Boot Option #3 | | Sets the system boot order. | |

| Setup Item | Options | Help Text | Comments |
|---------------------------|----------|--|---|
| Fast Boot | Disabled | | |
| Hard Drive BBS Priorities | | Set the order of the legacy devices in this group. | Set boot order in each group of the same kind, such as HDD, network |

3.6 Save & Exit Screen

The Save & Exit screen allows the user to choose whether to save or discard the configuration changes made on the other screens. It also allows the user to restore the server to the factory defaults or to save or restore them to set of user-defined default values.

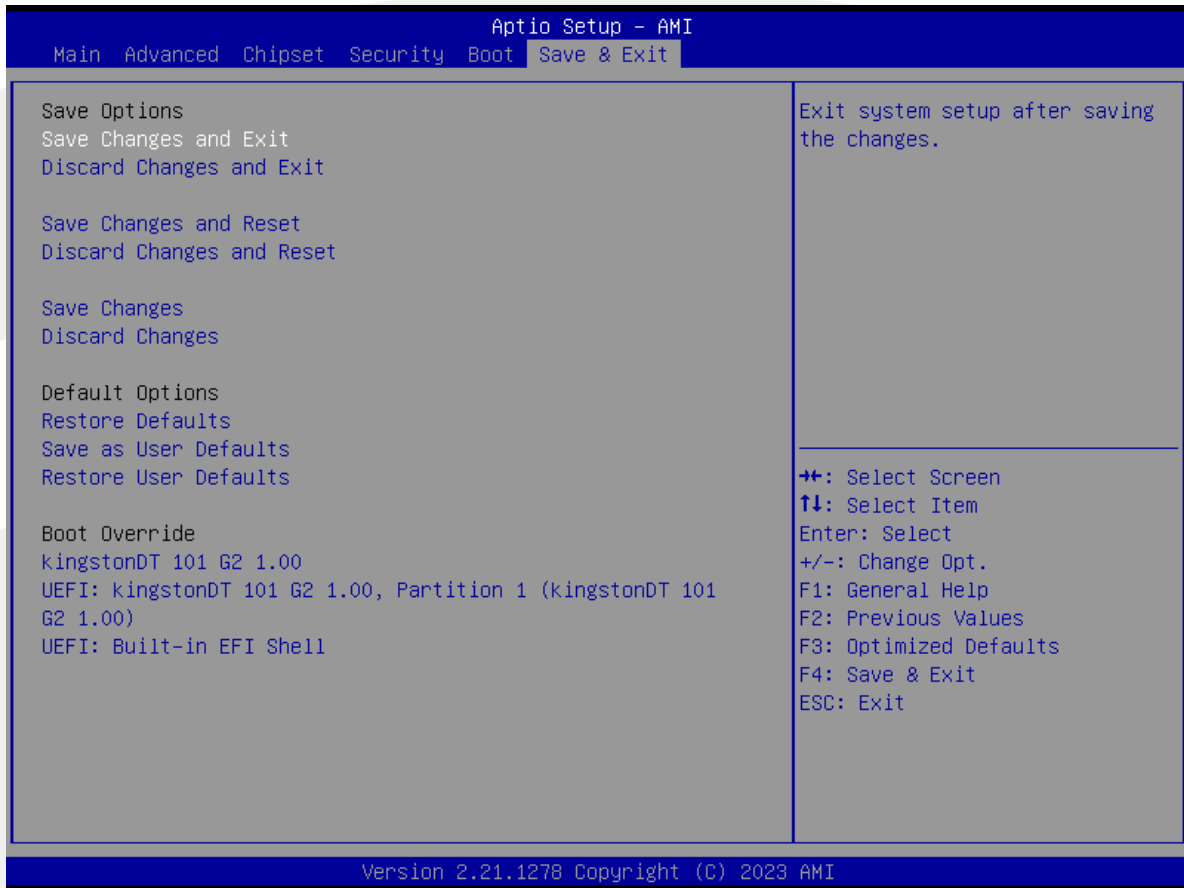

| Setup Item | Options | Help Text | Comments |
|---------------------------|---------|--|--|
| Save & Exit | | | |
| Save Options | | | |
| Save Changes and Exit | | Exit system setup after saving the changes. | User is prompted for confirmation only if any of the setup fields were modified. |
| Discard Changes and Exit | | Exit system setup without saving any changes. | |
| Save Changes and Reset | | Reset the system after saving the changes. | |
| Discard Changes and Reset | | Reset system setup without saving and changes. | |
| Save Changes | | Save Changes done so far to any of the setup options. | |
| Discard Changes | | Discard Changes done so far to any or the setup options. | |

| Setup Item | Options | Help Text | Comments |
|----------------------------|---------|--|--|
| Default Options | | | |
| Restore Defaults | | Restore/Load Default values for all the setup options. | |
| Save as User Defaults | | Save the changes done so far as User Defaults. | |
| Restore User Defaults | | Restore the User Defaults to all the setup options. | |
| Boot Override | | | |
| Shows the Device can boot. | | | Note: Shown When boot devices existed. |

第四章 Electrical Specifications

4.1 Input Power - General Considerations

The Compact, Basic and Extended Module Modules shall use a single main power rail with a nominal value of +12V. The Mini Module shall support a wide range power supply of 4.75V to 20.0V. In addition, the Mini Module shall be optimized for 5V operation and Module vendors should report Module power figures at 5V, 12V and 18V input voltages.

Two additional rails are specified: a +5V standby power rail and a +3V battery input to power the Module Real-time Clock (RTC) circuit in the absence of other power sources. The +5V standby rail may be left unconnected on the Carrier Board if the standby functions are not required by the application. Likewise, the +3V battery input may be left open if the application does not require the RTC to keep time in the absence of the main and standby sources. There may be Module specific concerns regarding storage of system setup parameters that may be affected by the absence of the +5V standby and / or the +3V battery.

The rationale for this power-delivery scheme is:

- Module pins are scarce. It is more pin-efficient to bring power in on a higher voltage rail.
- Single supply operation is attractive to many users.
- Lithium ion battery packs for mobile systems are most prevalent with a +14.4V output. This is well suited for the +12V main power rail.
- Contemporary chipsets have no power requirements for +5V other than to provide a reference voltage for +5V tolerant inputs. No COM Express Module pins are allocated to accept +5V except for the +5V standby pins. In the case of an ATX supply, the switched (non standby) +5V line would not be used for the COM Express Module, but it might be used elsewhere on the Carrier Board.

4.2 Input Power - Current Load

The Module connector pins limit the amount of power that can be brought into the COM Express Module. The limits are different for Module Pin-out Type 10 vs. Pin-out Types 6 and 7, based on the number of 12V power pins as Pin-out Type 10 has fewer pins available.

Table 4.1: Input Power - Pin-Out Type 10 Modules (Single Connector, 220 pins)

| Power Rail | Module Pin Current Capability (Amps) | Nominal Input (Volts) | Input Range (Volts) | Derated Input (Volts) | Max Input Ripple (mV) | Max Module Input Power (w. derated input) (Watts) | Assumed Conversion Efficiency | Max Load Power (Watts) |
|-------------------|--------------------------------------|-----------------------|---------------------|-----------------------|-----------------------|---|-------------------------------|------------------------|
| VCC_12V | 6 | 12 | 11.4 - 12.6 | 11.4 | +/-100 | 68 | 85% | 58 |
| Wide input (Mini) | 6 | | 4.75 – 20.0 | 4.75 | +/-100 | 28 | | |
| VCC_5V_SBY | 2 | 5 | 4.75 - 5.25 | 4.75 | +/-50 | 9 | | |
| VCC_RTC | 0.5 | 3 | 2.0 - 3.3 | | +/-20 | | | |

Table 4.2: Input Power - Pin-Out Type 6/7 Modules (Dual Connector, 440 pins)

| Power Rail | Module Pin Current Capability (Amps) | Nominal Input (Volts) | Input Range (Volts) | Derated Input (Volts) | Max Input Ripple (mV) | Max Module Input Power (w. derated input) (Watts) | Assumed Conversion Efficiency | Max Load Power (Watts) |
|------------|--------------------------------------|-----------------------|---------------------|-----------------------|-----------------------|---|-------------------------------|------------------------|
| VCC_12V | 12 | 12 | 11.4 - 12.6 | 11.4 | +/-100 | 137 | 85% | 116 |
| VCC_5V_SBY | 2 | 5 | 4.75 - 5.25 | 4.75 | +/-50 | 9 | | |
| VCC_RTC | 0.5 | 3 | 2.0 - 3.3 | | +/-20 | | | |

The ripple voltage, if present, must not cause the input voltage range to be exceeded.

4.3 Input Power - Sequencing

COM Express input power sequencing requirements are as follows:

- VCC_RTC shall come up at the same time or before VCC_5V_SBY comes up(if use)
 - VCC_5V_SBY shall come up at the same time or before VCC_12V comes up(if use)
 - PWR_OK shall be active at the same time or after VCC_12V comes up(if use)
 - PWR_OK shall be inactive at the same time or before VCC_12V goes down(if use)
 - VCC_12V shall go down at the same time or before VCC_5V_SBY goes down
 - VCC_5V_SBY shall go down at the same time or before VCC_RTC goes down(if use)
- Wide input (Mini) shall follow the power sequencing of the VCC_12V

Figure 4-1: Power Sequencing

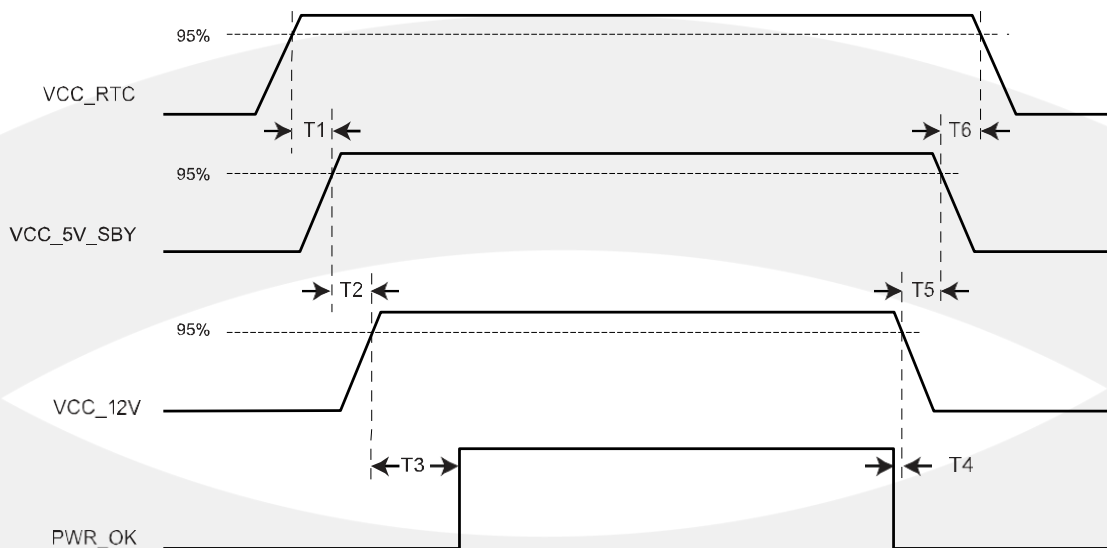

Table 4.3: Power Sequencing

| | | |
|----|---------------------------------|-------------|
| T1 | VCC_RTC rise to VCC_5V_SBY rise | ≥ 0 ms |
| T2 | VCC_5V_SBY rise to VCC_12V rise | ≥ 0 ms |
| T3 | VCC_12V rise to PWROK rise | ≥ 0 ms |
| T4 | PWR_OK fall to VCC_12V fall | ≥ 0 ms |
| T5 | VCC_12V fall to VCC_5V_SBY fall | ≥ 0 ms |
| T6 | VCC_5V_SBY fall to VCC_RTC fall | ≥ 0 ms |

4.4 Input Power - Rise Time

The input voltages to the COM Express Module VCC_12V, wide input (Mini) and VCC_5V_SBY if used shall rise from $\leq 10\%$ of nominal to within the regulation ranges within 0.1 ms to 20 ms ($0.1 \text{ ms} \leq T_2 \leq 20 \text{ ms}$). There must be a smooth and continuous ramp of each DC output voltage from 10% to 90% of its final set point within the regulation band. The smooth turn-on requires that, during the 10% to 90% portion of the rise time, the slope of the turn-on waveform must be positive and have a value of between 0 V/ms and $[\text{Vout, nominal} / 0.1] \text{ V/ms}$. Also, for any 5ms segment of the 10% to 90% rise time waveform, a straight line drawn between the end points of the waveform segment must have a slope $\geq [\text{Vout, nominal} / 20] \text{ V/ms}$.

Figure 4-2: Input Power Rise Time

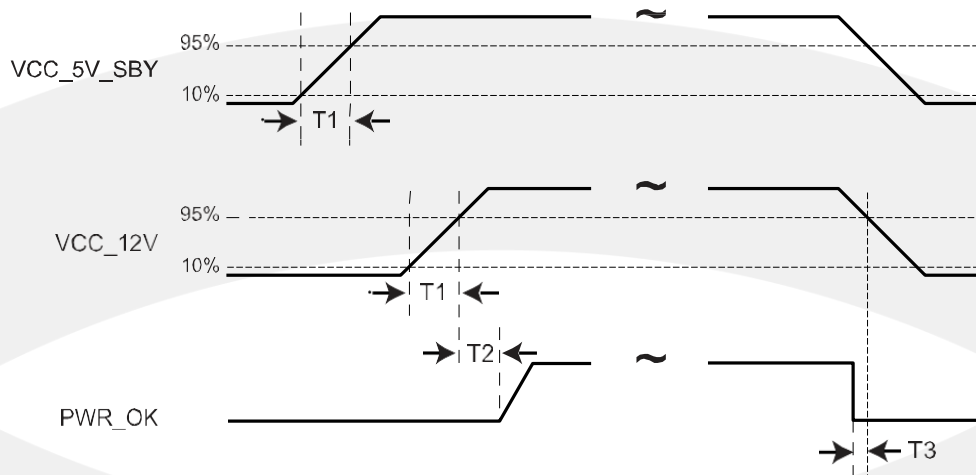

- $T1, \text{min} = 0,1 \text{ ms}$
- $T1, \text{max} = 20 \text{ ms}$
- $T2 \geq 0 \text{ ms}$
- $T3 \geq 0 \text{ ms}$

The values chosen were selected to be compatible and enable use of ATX specification R2.2.

4.5 Signal Integrity Requirements

The signal groups listed in the following table have signal-integrity concerns that should be accounted for in Module and Carrier Board designs. A general description is shown in the table for reference only. The designer should consult the relevant interface specification documents for complete information.

Table 4.4: Signal Integrity Requirements

| Signal Group | General Description | Source Spec Reference |
|--------------------|---|--------------------------------------|
| Gigabit Ethernet | Differential pairs | IEEE 802.3 Specification |
| LVDS | 100Ω edge coupled differential pairs | National Semiconductor LVDS web site |
| PCI and LPC clocks | 50Ω single ended ground-referenced | |
| PCI Express | Differential pairs | PCI SIG - PCI Express Specification |
| PCI Express clocks | 100Ω edge couple differential pair, ground-referenced | |
| Serial ATA | Differential pairs | SATA Specification |
| USB | Differential pairs | USB 2.0 Specification |
| 10GBASE-KR | Differential pairs | IEEE 802.3 Specification |
| USB SS | Differential pairs | USB 3.0 Specification |
| SPI | 50Ω single ended ground-referenced | |
| eSPI | 50Ω single ended ground-referenced | |

附录

附一：术语表

ACPI 高级配置和电源管理

ACPI 规范允许操作系统控制计算机及其附加设备的大部份电能。

BIOS 基本输入/输出系统

是在 PC 中包含所有的输入/输出控制代码界面的软件。它在系统启动时进行硬件检测，开始操作系统的运作，在操作系统和硬件之间提供一个界面。BIOS 是存储在一个只读存储器芯片内。

BUS 总线

在计算机系统中，不同部件之间交换数据的通道，是一组硬件线路。我们所指的 BUS 通常是 CPU 和主内存元件内部的局部线路。

Chipset 芯片组

是为执行一个或多个相关功能而设计的集成芯片。我们指的是由南桥和北桥组成的系统级芯片组，他决定了主板的架构和主要功能。

CMOS 互补金属

氧化物半导体。是一种被广泛应用的半导体类型。它具有高速、低功耗的特点。我们指的 CMOS 是在主板上的 CMOS RAM 中预留的一部份空间，用来保存日期、时间、系统信息和系统参数设定信息等。

COM 串口

一种通用的串行通信接口，一般采用标准 DB9 公头接口连接方式。

DIMM 双列直插式内存模块

是一个带有内存芯片组的小电路板。提供 64bit 的内存总线宽度。

DRAM 动态随机存取存储器

是一个普通计算机的通用内存类型。通常用一个晶体管和一个电容来存储一个位。随着技术的发展，DRAM 的类型和规格已经在计算机应用中变得越来越多样化。例如现在常用的就有 SDRAM、DDR SDRAM 和 RDRAM。

i2c

Inter-Integrated Circuit 总线是一种由 PHILIPS 公司开发的两线式串行总线，用于连接微控制器及其外围设备。

LAN 局域网络接口

一个小区域内相互关联的计算机组成的一个计算机网络，一般是在一个企事业单位或一栋建筑物。局域网一般由服务器、工作站、一些通信链接组成，一个终端可以通过电线访问数据和设备的任何地方，许多用户可以共享昂贵的设备和资源。

LED 发光二极管

一种半导体设备，当电流流过时它会被点亮，通常用来把信息非常直观地表示出来，例如表示电源已经导通或硬盘驱动器正在工作等。

PnP 即插即用

允许 PC 对外接设备进行自动配置，不用用户手动操作系统就可以自己工作的一种规格。为实现这个特点，BIOS 支持 PnP 和一个 PnP 扩展卡都是必需的。

POST 上电自检

在启动系统期间，BIOS 会对系统执行一个连续的检测操作，包括检测 RAM，键盘，硬盘驱动器等，看它们是否正确连接和是否正常工作。

PS/2

由 IBM 发展的一种键盘和鼠标连接的接口规范。PS/2 是一个仅有 6PIN 的 DIN 接口，也可以用以连接其他的设备，比如调制解调器。

USB 通用串行总线

一种适合低速外围设备的硬件接口，一般用来连接键盘、鼠标等。一台 PC 最多可以连接 127 个 USB 设备，提供一个 12Mbit/s 的传输带宽；USB 支持热插拔和多数数据流功能即在系统工作时可以插入 USB 设备，系统可以自动识别并让插入的设备正常。

深圳智锐通科技有限公司
Shenzhen Zrt Co., Ltd.



智锐通公众号

&



智锐通抖音号

- 📍 集团总部：深圳市宝安区碧桂园凤凰智谷A栋21楼
- 📍 南京分公司：南京市江宁区万科都荟天地B2栋7楼
- ☎ 400-838-6869