

1.Specifications:

Model	MD2060B6-6G
Graphics Processing Unit	NVIDIA GeForce RTX2060(Turing)
NVIDIA CUDA Core	1920
Tensor Core	240
RT Core	30
Bus Type	MXM3 .1 / up to PCI Express 3.0
Graphics Clock	1365MHz / 1680MHz (Boost)
Single Precision FLOPS	7343GFLOPS
Double Precision FLOPS	226.1GFLOPS
Memory Size	6G 192bit GDDR6
Memory Clock	1750MHz (14.0 Gbps)
Memory Bandwidth	336.0GB/s
Display Features	DP_A: Display Port1.4++ DP_B: Display Port1.4++ DP_C: HDMI2.0 DP_D: Display Port1.4++
Max Resolution	DP:7680x4320@120Hz HDMI:3840x2160@60Hz
Board Power	139W
Board Dimensions	MXM Graphics Module Version 3.1 Type B (105x82mm)
Number of output Channel	4
Operation System	Windows 7/10 64bit · Linux 64bit
VIN Range	DC 12~19V, 3.3V & 5V; +/-5%

OpenGL	4.6
OpenCL	1.2
DirectX	12
Video Playback	H.265, VC1, MPEG2 1080P

Operating Temperature	0~45°C
Storage Temperature	-20~75°C
Operating Humidity	0~95% (non-condensing)
Storage Humidity	10~90%

Surround (Landscape)	Surround (Portrait)
2x1(3840x1080@60Hz)	2x1(2160x1920@60Hz)
1x2(1920x2160@60Hz)	1x2(1080x3840@60Hz)
3x1(5760x1080@60Hz)	3x1(3240x1920@60Hz)
1x3(1920x3240@60Hz)	1x3(1080x5760@60Hz)
4x1(7680x1080@60Hz)	4x1(1080x7680@60Hz)
1x4(7680x1080@60Hz)	1x4(1080x7680@60Hz)
2x2(3840x2160@60Hz)	2x2(2160x3840@60Hz)

**Total resolution based on every display resolution is 1920*1080@60Hz.*

2.Block Diagram:

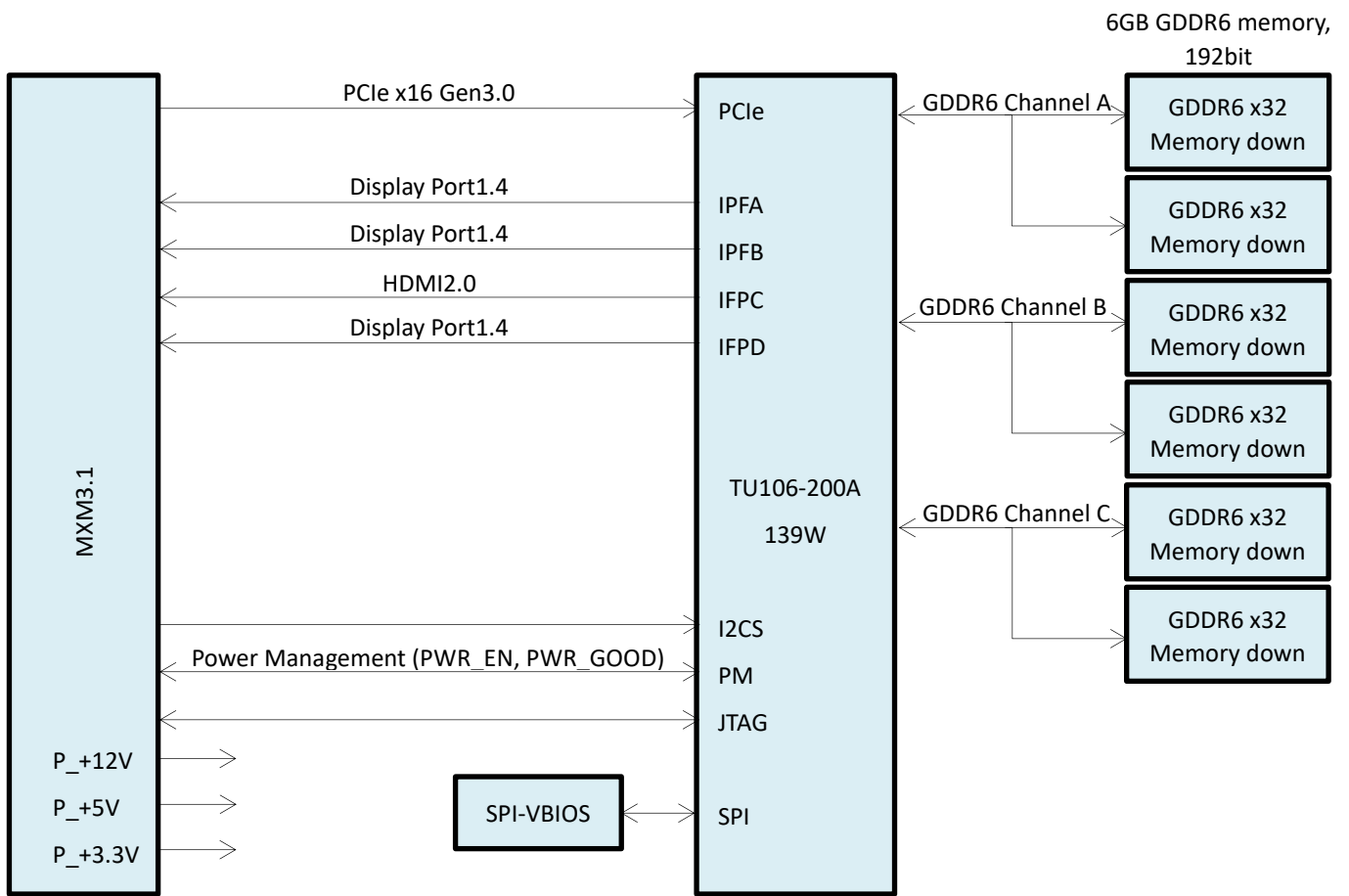

3.MXM Board Outlines:

Figure 3.1 shows the board outlines (top side view) for Type B MXM modules. An additional system keep-out of 0.5mm[0.020] per side is allowed on the PCB to accommodate whatever means of production panelization is required. This additional clearance is above and beyond the dimensional limits presented here. The location of these features is not specified or controlled.

Figure 3.1: Board Outlines

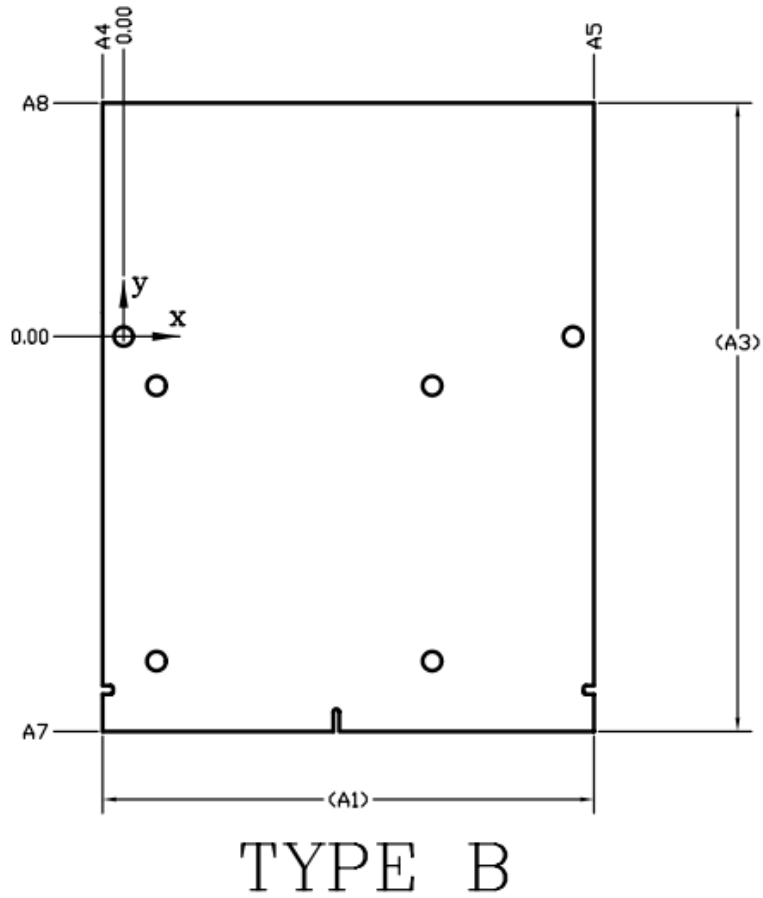

Table 3.1: Board Outline Dimensions

Symbol	[mm]			[in]		
	min	nom	max	min	nom	max
A1		82.00			3.228	
A3		105.00			4.134	
A4	3.37	3.50	3.63	0.133	0.138	0.143
A5	78.37	78.50	78.63	3.085	3.091	3.096
A7	65.87	66.00	66.13	2.593	2.598	2.604
A8	38.87	39.00	39.13	1.530	1.535	1.541

Figure 3.2: Board Slots Detail

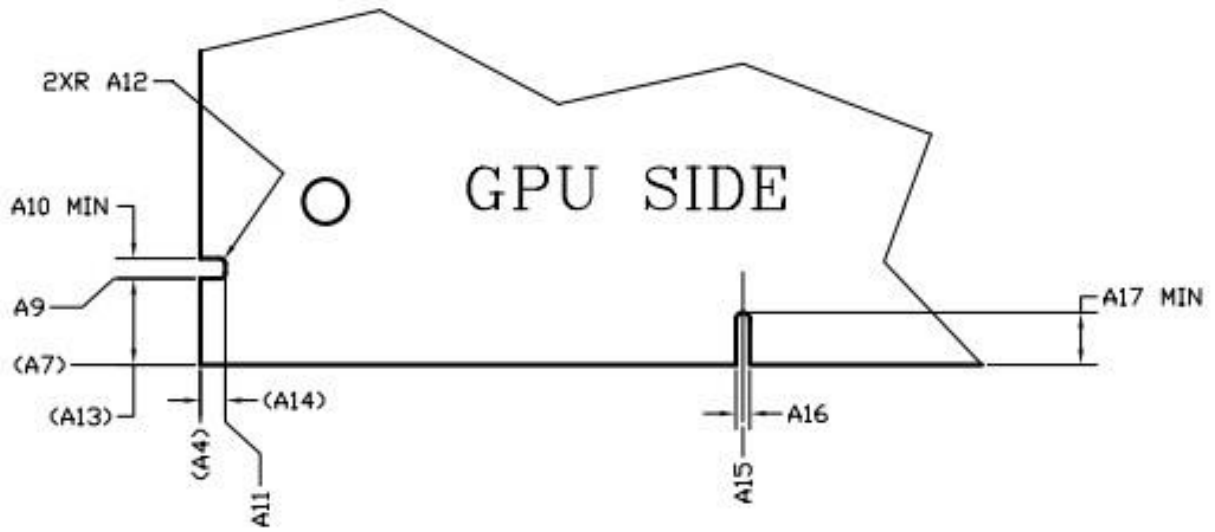

Table 3.2: Board Slots Dimensions

Symbol	[mm]			[in]		
	min	nom	max	min	nom	max
A4		3.50			0.138	
A7		66.00			2.598	
A9	59.67	59.80	59.93	2.349	2.354	2.359
A10	1.45			0.057		
A11	1.57	1.70	1.83	0.062	0.067	0.072
A12	0.32	0.50	0.58	0.013	0.020	0.023
A13		6.20			0.244	
A14		1.80			0.071	
A15	35.37	35.50	35.63	1.393	1.398	1.403
A16	0.95	1.00	1.05	0.037	0.039	0.041
A17	3.75			0.148		

4.MXM PCB Mounting Holes:

All MXM version 3.1 modules have 6 holes. Two are used to secure the board to the system and the other four to fasten the thermal solution to the module.

Figure 4.1: Mounting Holes

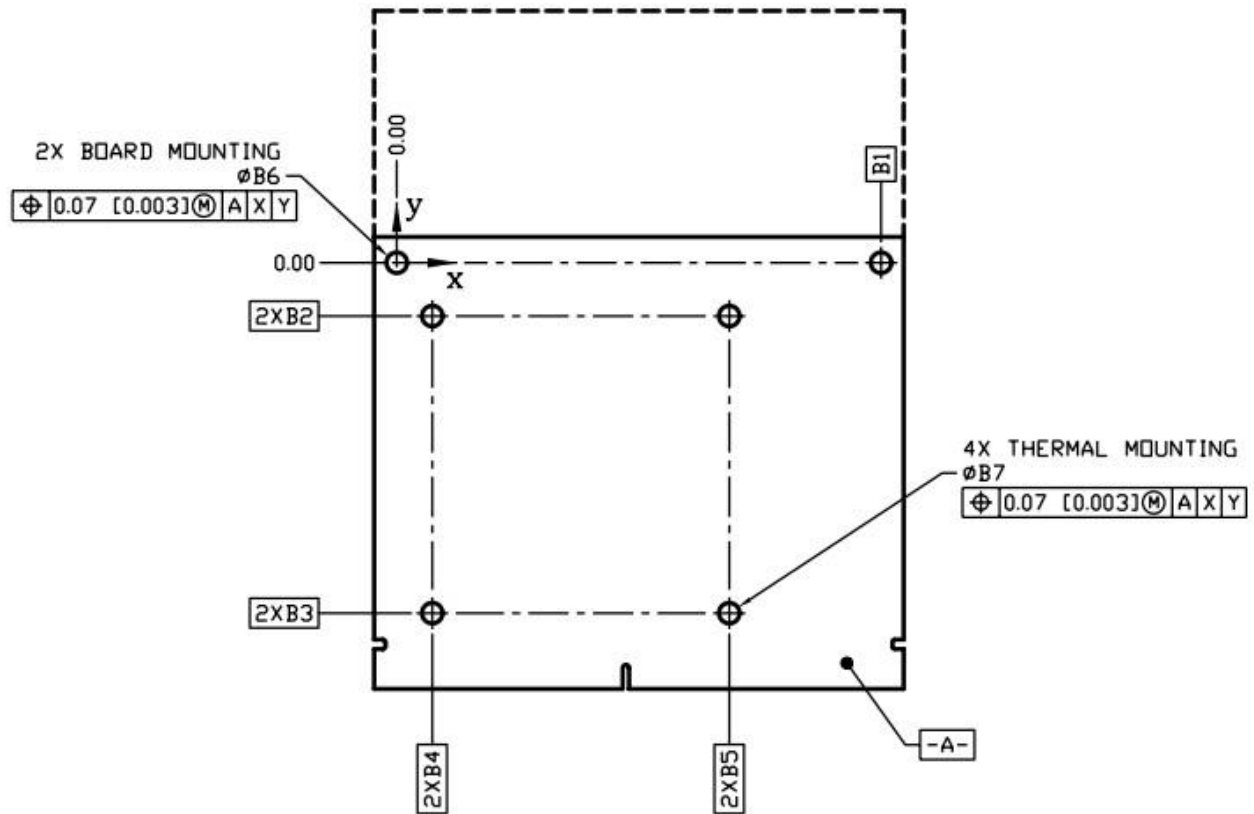

Table 4.1: Mounting Holes Dimensions

Symbol	[mm]			[in]		
	min	nom	max	min	nom	max
B1		75.00			2.953	
B2		8.25			0.325	
B3		54.25			2.136	
B4		5.50			0.217	
B5		51.50			2.028	
B6	3.07	3.20	3.33	0.121	0.126	0.131
B7	3.07	3.20	3.33	0.121	0.126	0.131

5.Connector Pinout:

Table 5.1, Table 5.2 and Table 5.3 list the connector pinout.

Table 5.1: Connector Pinout

Pin	Signal Name	Pin	Signal Name	Pin	Signal Name	Pin	Signal Name
E1	PWR_SRC	E2	PWR_SRC	51	PEX_RX15	52	GND
E3	GND	E4	GND	53	GND	54	PEX_TX14#
1	5V	2	PRSNT_R	55	PEX_RX14#	56	PEX_TX14
3	5V	4	WAKE	57	PEX_RX14	58	GND
5	5V	6	PWR_GOOD	59	GND	60	PEX_TX13#
7	5V	8	PWR_EN	61	PEX_RX13#	62	PEX_TX13
9	5V	10	27MHZ_REF	63	PEX_RX13	64	GND
11	GND	12	GND	65	GND	66	PEX_TX12#
13	GND	14	LVDS_U_HPD DP_F_HPD	67	PEX_RX12#	68	PEX_TX12
15	GND	16	RSVD	69	PEX_RX12	70	GND
17	GND	18	PWR_LEVEL	71	GND	72	PEX_TX11#
19	PEX_STD_SW#	20	TH_OVERT#	73	PEX_RX11#	74	PEX_TX11
21	VGA_DISABLE#	22	TH_ALERT#	75	PEX_RX11	76	GND
23	PNL_PWR_EN	24	TH_PWM	77	GND	78	PEX_TX10#
25	PNL_BL_EN	26	GPIO0	79	PEX_RX10#	80	PEX_TX10
27	PNL_BL_PWM	28	GPIO1	81	PEX_RX10	82	GND
29	HDMI_CEC	30	GPIO2	83	GND	84	PEX_TX9#
31	LVDS_L_HPD DP_E_HPD	32	SMB_DAT	85	PEX_RX9#	86	PEX_TX9
33	LVDS_DDC_DAT NC	34	SMB_CLK	87	PEX_RX9	88	GND
35	LVDS_DDC_CLK NC	36	GND	89	GND	90	PEX_TX8#
37	GND	38	OEM0	91	PEX_RX8#	92	PEX_TX8
39	OEM1	40	OEM2	93	PEX_RX8	94	GND
41	OEM3	42	OEM4	95	GND	96	PEX_TX7#
43	OEM5	44	OEM6	97	PEX_RX7#	98	PEX_TX7
45	OEM7	46	GND	99	PEX_RX7	100	GND
47	GND	48	PEX_TX15#	101	GND	102	PEX_TX6#
49	PEX_RX15#	50	PEX_TX15	103	PEX_RX6#	104	PEX_TX6

Table 5.2: Connector Pinout(continued)

Pin	Signal Name	Pin	Signal Name	Pin	Signal Name	Pin	Signal Name
105	PEX_RX6	106	GND	153	PEX_REFCLK#	154	PEX_CLK_REQ#
107	GND	108	PEX_TX5#	155	PEX_REFCLK	156	PEX_RST#
109	PEX_RX5#	110	PEX_TX5	157	GND	158	VGA_DDC_DAT
111	PEX_RX5	112	GND	159	JTAG_TDO	160	VGA_DDC_CLK
113	GND	114	PEX_TX4#	161	JTAG_TDI	162	VGA_VSYNC
115	PEX_RX4#	116	PEX_TX4	163	JTAG_TCLK	164	VGA_HSYNC
117	PEX_RX4	118	GND	165	JTAG_TMS	166	GND
119	GND	120	PEX_TX3#	167	JTAG_TRST#	168	VGA_RED
121	PEX_RX3#	122	PEX_TX3	169	DP_F_L3 LVDS_UCLK#	170	VGA_GREEN
123	PEX_RX3	124	GND	171	DP_F_L3 LVDS_UCLK	172	VGA_BLUE
125	GND	126	KEY	173	GND	174	GND
127	KEY	128	KEY	175	DP_F_AUX LVDS_UTX3#	176	DP_E_L3 LVDS_LCLK#
129	KEY	130	KEY	177	DP_F_AUX LVDS_UTX3	178	DP_E_L3 LVDS_LCLK
131	KEY	132	KEY	179	GND	180	GND
133	GND	134	GND	181	DP_F_L0 LVDS_UTX2#	182	DP_E_AUX LVDS_LTX3#
135	PEX_RX2#	136	PEX_TX2#	183	DP_F_L0 LVDS_UTX2	184	DP_E_AUX LVDS_LTX3
137	PEX_RX2	138	PEX_TX2	185	GND	186	GND
139	GND	140	GND	187	DP_F_L1 LVDS_UTX1#	188	DP_E_L0 LVDS_LTX2#
141	PEX_RX1#	142	PEX_TX1#	189	DP_F_L1 LVDS_UTX1	190	DP_E_L0 LVDS_LTX2
143	PEX_RX1	144	PEX_TX1	191	GND	192	GND
145	GND	146	GND	193	DP_F_L2 LVDS_UTX0#	194	DP_E_L1 LVDS_LTX1#
147	PEX_RX0#	148	PEX_TX0#	195	DP_F_L2 LVDS_UTX0	196	DP_E_L1 LVDS_LTX1
149	PEX_RX0	150	PEX_TX0	197	GND	198	GND
151	GND	152	GND	199	DP_C_L0#	200	DP_E_L2 LVDS_LTX0#

Table 5.3: Connector Pinout(continued)

Pin	Signal Name	Pin	Signal Name	Pin	Signal Name	Pin	Signal Name
201	DP_C_L0	202	DP_E_L2 LVDS_LTX0	243	RSVD	244	GND
203	GND	204	GND	245	RSVD	246	DP_B_L0#
205	DP_C_L1#	206	DP_D_L0#	247	RSVD	248	DP_B_L0
207	DP_C_L1	208	DP_D_L0	249	RSVD	250	GND
209	GND	210	GND	251	GND	252	DP_B_L1#
211	DP_C_L2#	212	DP_D_L1#	253	DP_A_L0#	254	DP_B_L1
213	DP_C_L2	214	DP_D_L1	255	DP_A_L0	256	GND
215	GND	216	GND	257	GND	258	DP_B_L2#
217	DP_C_L3#	218	DP_D_L2#	259	DP_A_L1#	260	DP_B_L2
219	DP_C_L3	220	DP_D_L2	261	DP_A_L1	262	GND
221	GND	222	GND	263	GND	264	DP_B_L3#
223	DP_C_AUX#	224	DP_D_L3#	265	DP_A_L2#	266	DP_B_L3
225	DP_C_AUX	226	DP_D_L3	267	DP_A_L2	268	GND
227	RSVD	228	GND	269	GND	270	DP_B_AUX#
229	RSVD	230	DP_D_AUX#	271	DP_A_L3#	272	DP_B_AUX
231	RSVD	232	DP_D_AUX	273	DP_A_L3	274	DP_B_HPDP
233	RSVD	234	DP_C_HPDP	275	GND	276	DP_A_HPDP
235	RSVD	236	DP_D_HPDP	277	DP_A_AUX#	278	3V3
237	RSVD	238	RSVD	279	DP_A_AUX	280	3V3
239	RSVD	240	3V3	281	PRSNT_L	-	
241	RSVD	242	3V3				

6.MXM Connector:

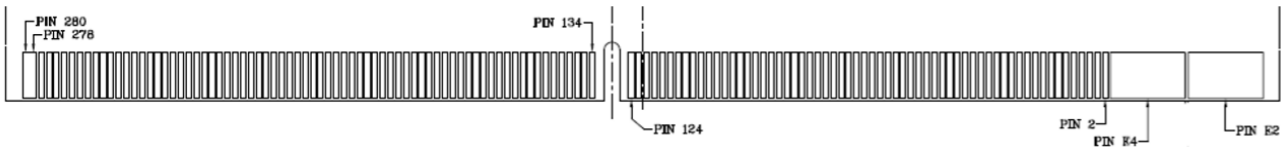

Figure 6.1 MXM Connector (Card Top)

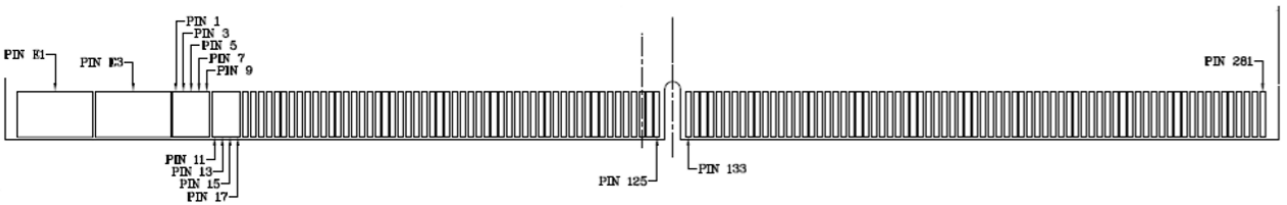

Figure 6.2 MXM Connector (Card Bottom)

9.DisplayPort Interface:

DC blocking capacitors of DisplayPort must be placed on the system board. In addition to the MXM implementation of Dual-mode DisplayPort requires the circuit in Figure 9.1 on the AUX lines for proper dongle detection. The HPD signal conditioning must also be placed on the system board.

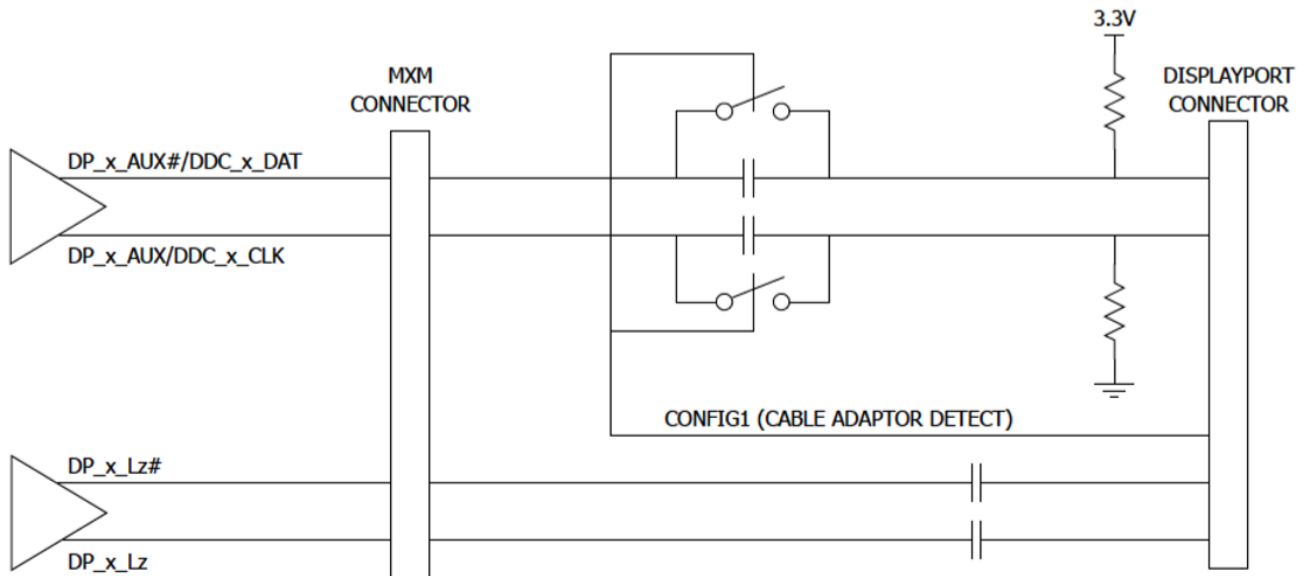

Figure 9.1 Dual-mode DisplayPort Implementation

10.DVI/HDMI on DP Interface:

Native DVI or HDMI connector support can be implemented using a DisplayPort interface.

Additional circuitry is required on the system and the proper signal mapping must be observed. As Figure 10.1 shows, 499Ω 1% pull-down resistors to ground on the DP lane signals must be placed on the connector side of AC coupling capacitors gated by a FET to limit the leakage. Additionally level shifting circuits must also be implemented on DDC Data and Clock.

Table 10.1 shows the mapping to connect the signals from the MXM connector to the HDMI/DVI connector.

Table 10.1: DisplayPort Multiplexed Signal Definition

Pin Name	DVI/HDMI
DP_xL0 DP_xL0#	TX_x_D2 TX_x_D2#
DP_x_L1 DP_x_L1#	TX_x_D1 TX_x_D1#
DP_x_L2 DP_x_L2#	TX_x_D0 TX_x_D0#
DP_x_L3 DP_x_L3#	TX_x_CLK TX_x_CLK#
DP_x_AUX DP_x_AUX#	DDC_x_CLK DDC_x_DAT

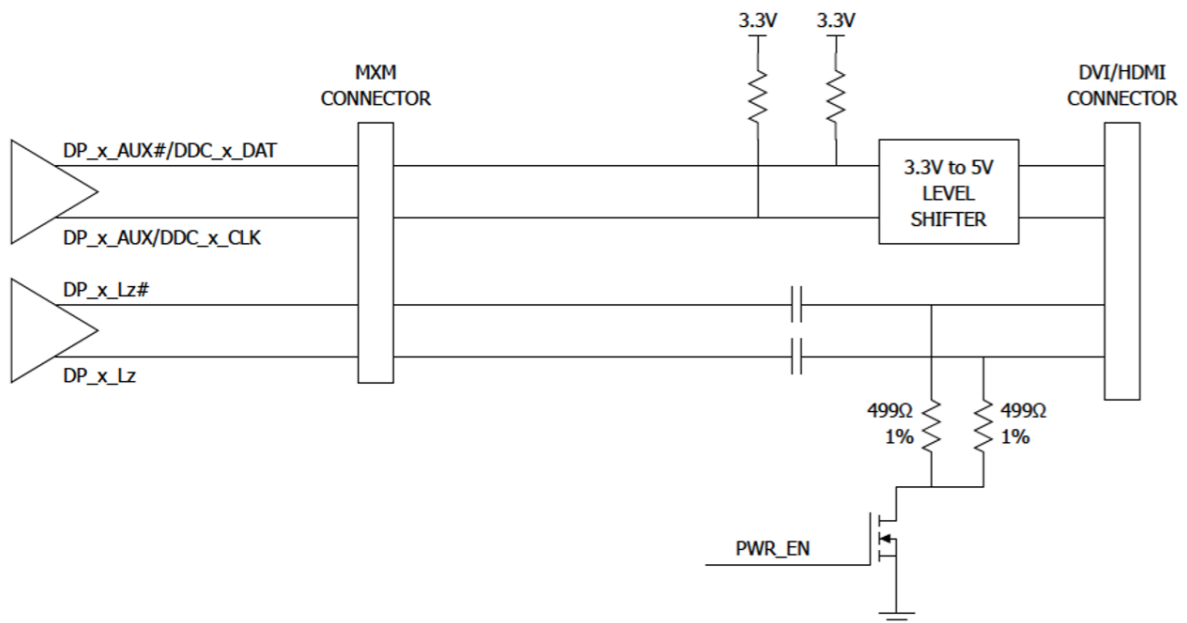
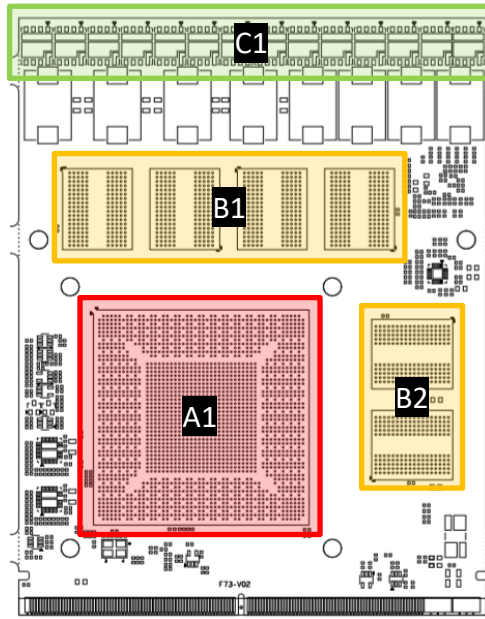

Figure 10.1 DVI/HDMI Implementation Using DP Interface

11.Thermal:



Components	Area	TDP	Height
GPU	A1	139W	2.6mm
Memory	B1	1.5W*4	0.9mm
Memory	B2	1.5W*2	0.9mm
Mosfet	C1	139W	0.75mm

Chipset		Specification
Dimensions		14.6*14.6mm
Stress	Maximum	75 PSI
	Normal	30-40 PSI

Cooling Suggestion:

- 1、显卡建议先固定在散热器上，散热器外径为 4mm，M2 的螺柱。
- 2、散热器的重量要用箱体来支撑固定。
- 3、显存和 MOS 要加导热垫。

Components	亮温满载限温（环温 45℃）
GPU	95℃
Memory	85℃
Mosfet	105℃

*显存和 MOS 由“探针”监测；GPU 由“Furmark (1920*1080)”监测。

12.Performance:

3Dmark13	17492	Cuda	
3Dmark11	E20344 P16841 X7694	single kernels	4926.13 / 226.533
3Dmark Vantage	59968	N=10 w/o streams	6035.8 / 233.922
Heaven	6214	N=10 with streams	5988.28 / 235.029
鲁大师	223626	N=10 batched	6070.81 / 234.276

AIDA64 GPGPU Benchmark

GPU: nVIDIA GeForce RTX 2060
 1680 MHz, 30 CUs, Driver 441.66

CPU: Intel Core i5 (Kaby Lake-S)
 3900 MHz, 6 cores, 6 threads

	GPU	x64 CPU
Memory Read	12581 MB/s	19648 MB/s
Memory Write	12070 MB/s	19282 MB/s
Memory Copy	274073 MB/s	18502 MB/s
Single-Precision FLOPS	7343 GFLOPS	742.7 GFLOPS
Double-Precision FLOPS	226.1 GFLOPS	371.4 GFLOPS
24-bit Integer IOPS	7247 GIOPS	329.8 GIOPS
32-bit Integer IOPS	7172 GIOPS	330.0 GIOPS
64-bit Integer IOPS	1635 GIOPS	46.36 GIOPS
AES-256	19163 MB/s	19468 MB/s
SHA-1 Hash	58102 MB/s	5885 MB/s
Single-Precision Julia	1914 FPS	219.2 FPS
Double-Precision Mandel	62.83 FPS	119.3 FPS

AIDA64 v5.90.4200 (c) 1995-2017 FinalWire Ltd.

Save Results Start Benchmark Close

TechPowerUp GPU-Z 2.26.0

Graphics Card Sensors Advanced Validation

Name: NVIDIA GeForce RTX 2060

GPU: TU106 Revision: A1

Technology: 12 nm Die Size: 445 mm²

Release Date: 2019 Transistors: 10800M

BIOS Version: 90.06.3F.00.AE

Subvendor: NVIDIA Device ID: 10DE 1F08 - 10DE 12FD

ROPs/TMUs: 48 / 120 Bus Interface: PCIe x16 3.0 @ x16 3.0

Shaders: 1920 Unified DirectX Support: 12 (12_1)

Pixel Fillrate: 80.6 GPixel/s Texture Fillrate: 201.6 GTexel/s

Memory Type: GDDR6 (Micron) Bus Width: 192 bit

Memory Size: 6144 MB Bandwidth: 336.0 GB/s

Driver Version: 26.21.14.4166 (NVIDIA 441.66) DCH / Win10 64

Driver Date: Dec 06, 2019 Digital Signature: WHQL

GPU Clock: 1365 MHz Memory: 1750 MHz Boost: 1680 MHz

Default Clock: 1365 MHz Memory: 1750 MHz Boost: 1680 MHz

NVIDIA SLI: Disabled

Computing: OpenCL CUDA DirectCompute DirectML

Technologies: Vulkan Ray Tracing PhysX OpenGL 4.6

NVIDIA GeForce RTX 2060 Close

13.Driver:

Windows 10 64bit: <https://cn.download.nvidia.com/Windows/466.77/466.77-desktop-win10-64bit-international-dch-whql.exe>

Windows 7 64bit: <https://cn.download.nvidia.com/Windows/466.77/466.77-desktop-win7-64bit-international-whql.exe>

Linux Aarch64: <https://cn.download.nvidia.com/XFree86/aarch64/460.84/NVIDIA-Linux-aarch64-460.84.run>

Linux 64bit: https://cn.download.nvidia.com/XFree86/Linux-x86_64/460.84/NVIDIA-Linux-x86_64-460.84.run

FreeBSD x64: https://cn.download.nvidia.com/XFree86/FreeBSD-x86_64/460.84/NVIDIA-FreeBSD-x86_64-460.84.tar.gz

The latest drive or the drive cannot be downloaded here, please log on the official website to download: <https://www.nvidia.cn/geforce/drivers/>

14. Dimensions:

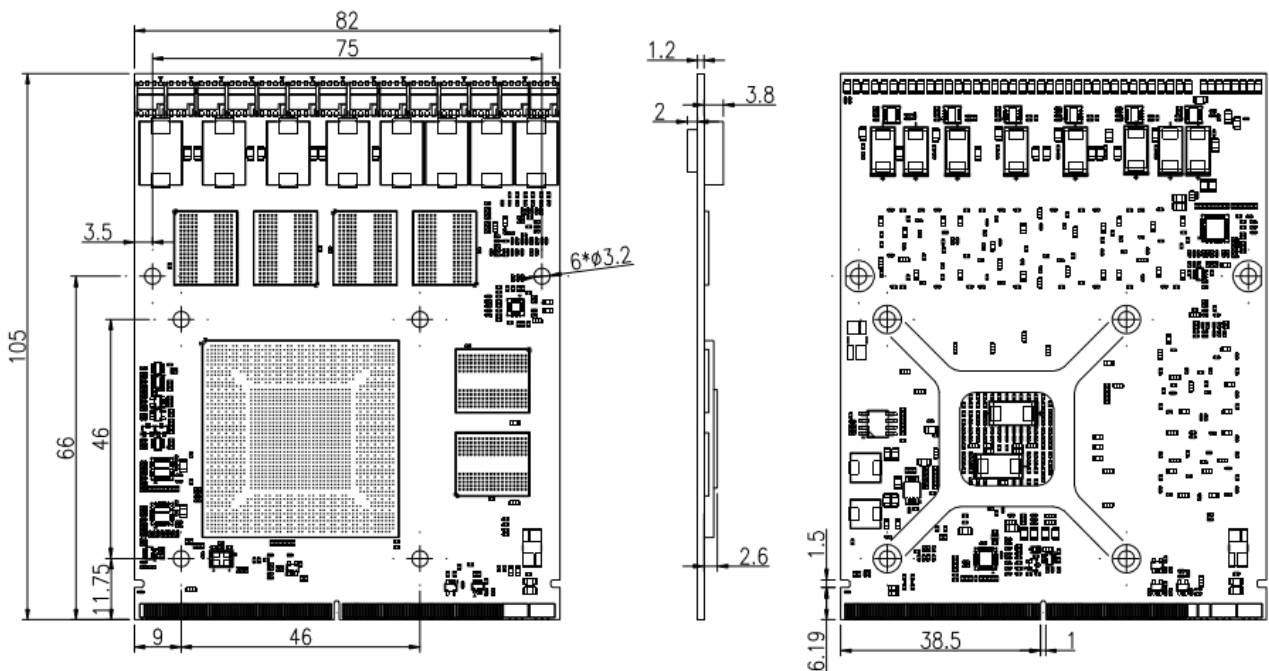

15.Photo:

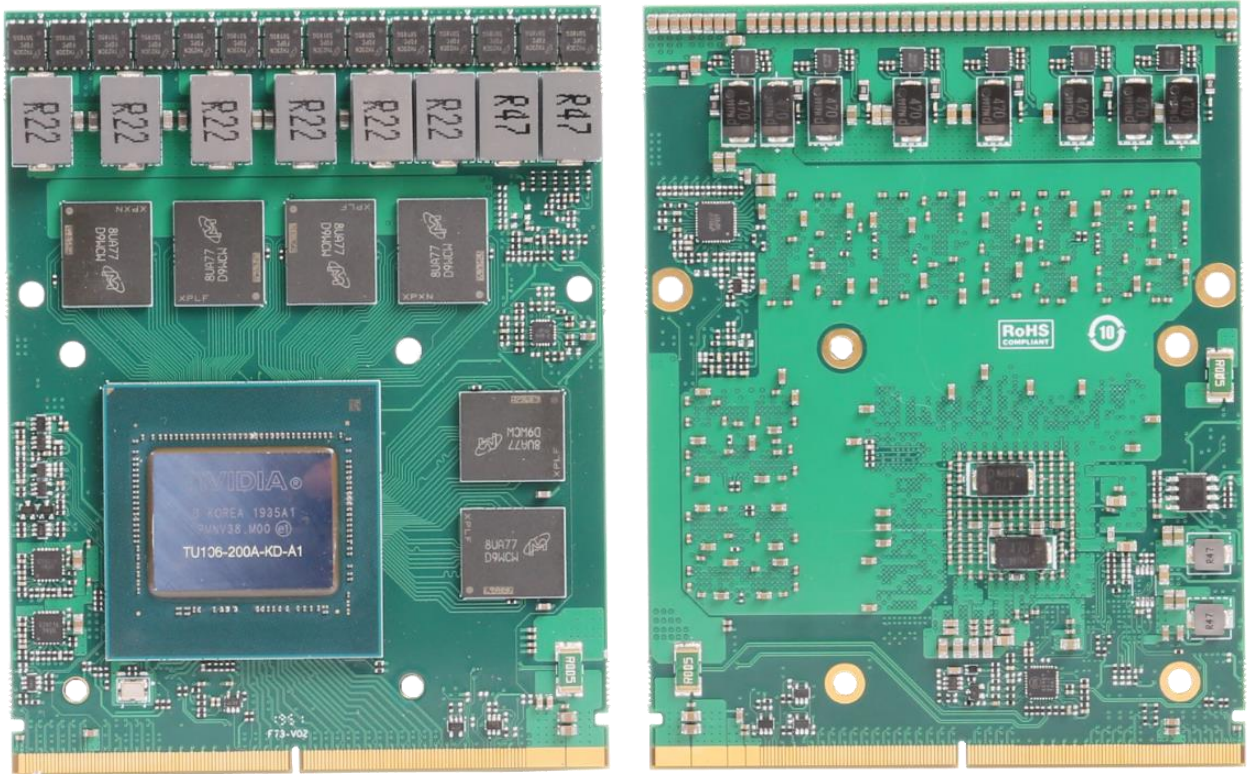

16.Cooling Option:

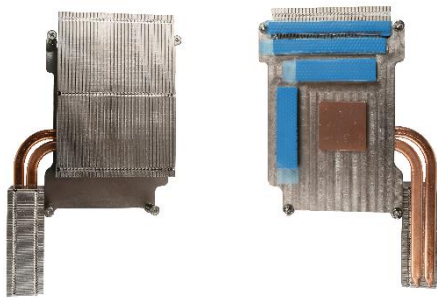

*需搭配风扇辅助散热。

1.ZRT.48-6243-00-A00	
Dimension	190*124.5*37.5m
Rated Speed	N/A
Out of Frame Lead Wires	N/A
Connector	N/A

17.Question:

故障	排除
不显示 (HDMI 输出)	1、4K 60Hz 显示屏，确认 HDMI 线材是否为 HDMI2.0。 2、将显示器分辨率降为 2K 60Hz。
设备管理员出现惊叹号	1、原系统显卡驱动删除干净。(请使用 Display Driver Uninstaller 删除， https://www.wagnardsoft.com/) 2、Windows 10 版本 16299 不支持，需更新至最新版 (17763、17134 均可)。 3、Windows 7 打补丁 KB2685811。 4、确认核显驱动是否已安装。(不需独立显卡显示) 5、安装在移动平台上，主板 BIOS 需关闭电池管理。
显卡不工作	量下 3V3/5V/2V/Reset 信号是否有电/短路？若有电，显卡就会工作。
显卡无法辨视	检查 PCIE LANE Numbering Reversal 设置。
安装 Linux 系统，图形界面异常/无限循环登陆界面，无法登录系统	装驱动的时，加上--no-opengl-files。 (禁用 opengl，若系统上有用到这套组件，将无法使用)
控制面板无法正常开启	仅可在独显显示时，才能正常开启；若使用集显显示，将无法正常开启。
集显及独显在 Win7 下，无法同时开启 3D 启动	打系统补丁 (KB2685811)，解压后，把所有文件 COPY 到 C 盘 根目录下运行 BAT 文件。
X86 在中标麒麟系统下，显卡驱动后集显输出不能进系统	将 xorg.conf 文件内容清空。

18.Part Number:

Model	Part Number	Specification
MD2060B6-6G	8.ZRT.80-6325-00-LFF	F73 RTX2060 6G 192bit GDDR6 256*32 DP+DP+HDMI+DP MXM Type B 14L-工包六十入
	8.ZRT.80-6325-03-LFF	F73 RTX2060 6G 192bit GDDR6 256*32 DP+DP+HDMI+DP MXM Type B 14L-ZRT 彩包二十入