



# ECM-SKY6U2

COM-Express Type6 核心板  
USER Manual V1.3

## USER MANUAL 用户手册

## 声明

本使用说明书内容如有变更，恕不另行通知。本公司并不对本使用说明书之适用性，适合做某种特殊用途之使用或其他任何事项做任何明示，或做其他形式之保证或担保。因此本公司将不对手册内容之错误，或因增减展示或以其他方法使用本手册所造成之直接，间接，突发性过、或继发性之损害负任何责任。

版权声明：

版权所有----深圳智锐通科技有限公司。未经本公司许可或依著作权法之规定许准，不得复制，节录和翻译使用说明书之任何内容。

## 安全须知

1	产品使用前，务必仔细阅读产品说明书。
2	对未准备安装的板卡，应将其保存在防静电保护袋中。
3	在从包装袋中拿板卡前，应将手先置于接地金属物体上一会儿，以释放身体及手中的静电。
4	在拿板卡时，需佩带静电保护手套，并且应该养成只触及边缘部份的习惯。
5	主板与电源连接时，请确认电源电压。
6	为避免人本被电击或产品被损坏，在每次对主板、板卡进行拔插或生新配置时须先关闭交流电源或将交流电源线从电源插座中拔掉。
7	在对板卡进行搬动前，先将交流电源线从电源插座中拔掉。
8	当您需连接或拔除任何设备前，须确定所有的电源线事先已被拔掉。
9	为避免频繁开关机对产品造成不必要的损伤,关机后,应至少等待30秒后再开机。
10	设备在使用过程时出现异常情况，请找专业人员处理。

# 目录

<b>第一章 产品介绍</b> .....	6
<b>1.1 产品规格</b> .....	6
<b>1.2 功能框图</b> .....	8
<b>1.3 产品料号</b> .....	9
<b>1.4 产品照片</b> .....	10
<b>1.5 散热器</b> .....	12
<b>1.6 安装视频</b> .....	13
<b>第二章 安装说明</b> .....	14
<b>2.1 接口/尺寸图</b> .....	14
<b>2.2 硬件安装</b> .....	16
<b>2.3 跳线功能设置</b> .....	16
<b>2.4 接口引脚定义</b> .....	16
<b>第三章 BIOS 程序设置</b> .....	20
<b>3.1 Main Screen</b> .....	21
<b>3.1.1 System Monitor</b> .....	23
<b>3.2 Advanced Screen</b> .....	24
<b>3.2.1 CPU Configuration Screen</b> .....	25
<b>3.2.1.1 CPU - Power Management Control</b> .....	27
<b>3.2.2 ACPI Settings Screen</b> .....	28
<b>3.2.3 Super IO Configuration</b> .....	29
<b>3.2.3.1 Serial Port 1 Configuration</b> .....	30
<b>3.2.4 SATA Configuration</b> .....	31

<b>3.2.5 USB Configuration</b> .....	32
<b>3.2.6 CSM Configuration</b> .....	34
<b>3.2.7 Watchdog Configuration</b> .....	35
<b>3.2.8 PXE Boot</b> .....	36
<b>3.3 Chipset Screen</b> .....	37
<b>3.3.1 System Agent (SA) Configuration</b> .....	38
<b>3.3.1.1 Graphics Configuration</b> .....	39
<b>3.3.2 PCH-IO Configuration</b> .....	41
<b>3.4 Security</b> .....	42
<b>3.5 Boot Screen</b> .....	43
<b>3.6 Save &amp; Exit Screen</b> .....	44
<b>第四章 Electrical Specifications</b> .....	46
<b>4.1 Input Power - General Considerations</b> .....	46
<b>4.2 Input Power - Current Load</b> .....	47
<b>4.3 Input Power - Sequencing</b> .....	48
<b>4.4 Input Power - Rise Time</b> .....	49
<b>4.5 Signal Integrity Requirements</b> .....	50
<b>附录</b> .....	51
<b>附一：术语表</b> .....	51

## 第一章 产品介绍

### 1.1 产品规格

Model		ECM-SKY6U2		
配置 Item	规格 Specification	描述 Describe		
处理器 Processor System	处理器 CPU	i7-6600U	i5-6300U	i3-6100U
	内核数 Core Number	2C/4T	2C/4T	2C/4T
	最高主频 Max. Speed	3.4GHz	3.0GHz	2.3GHz
	二级缓存 L2 Cache	4M	3M	3M
	功耗 TDP (W)	15W	15W	15W
	指令集 Instruction Set Extensions	SSE4.1, SSE4.2, AVX2		
	芯片组 Chipset	Integrated PCH-LP		
	BIOS	AMI EFI BIOS		
扩展插槽 Expansion Slot	PCI Express x4	1*PCIe 4x(Option 1*PCIe 2x+2*PCIe 1x)		
内存 Memory	规格 Technology	DDR4		
	最大容量 Max. Capacity	16G 2133MHz		
	插槽 Socket	2*SO-DIMM		
显示 Display	控制器 Controller	1*DDI support configurable HDMI/DVI/DP 1*DDI support configurable VGA 1*eDP to LVDS(optional eDP)		
	分辨率 Resolution	HDMI:4096*2304@24Hz DP:4096*2304@60Hz eDP:4096*2304@60Hz		
以太网 Ethernet	控制器 Controller	INTEL i219		
	连接器 Connector Type	COMe		

内部接口 Internal Connector	<b>USB 3.0</b>	4*USB 3.0
	<b>USB 2.0</b>	4*USB2.0
	<b>SATS3.0</b>	3*SATA3.0(Depend On CPU)
	<b>GPIO</b>	8-bit GPIO
	<b>LPC</b>	1*LPC
	<b>SMBUS</b>	1*SMBUS
	<b>看门狗 Watch Dog</b>	Support
	<b>TPM2.0</b>	1*TPM2.0
	<b>串口 COM</b>	1*COM
	<b>按钮 Button</b>	1*Power Button 1*Reset Button
	<b>其他 Others</b>	1*FAN
	<b>拓展 Connector</b>	2*COMe 220Pin
电源 Power Requirements	<b>电源类型 Power Type</b>	ATX: VCC,VSB AT: VCC
	<b>电源电压 Input Voltage</b>	最大 54 W
	<b>连接器 Connector type</b>	底板供电
环境 Environment	<b>工作温度 Operating Temperature</b>	0~60°C
	<b>存储温度 Storage Temperature</b>	-40~85°C
	<b>工作湿度 Operating Humidity</b>	20~90%(non-condensing)
物理特性 Physical	<b>尺寸 Dimensions</b>	95*95mm
	<b>PCB 颜色 Color</b>	Green
操作系统 OS	<b>Microsoft</b>	Windows 10 1809(RS5)
	<b>Linux</b>	Yocto 2.4 Rocko

## 1.2 功能框图

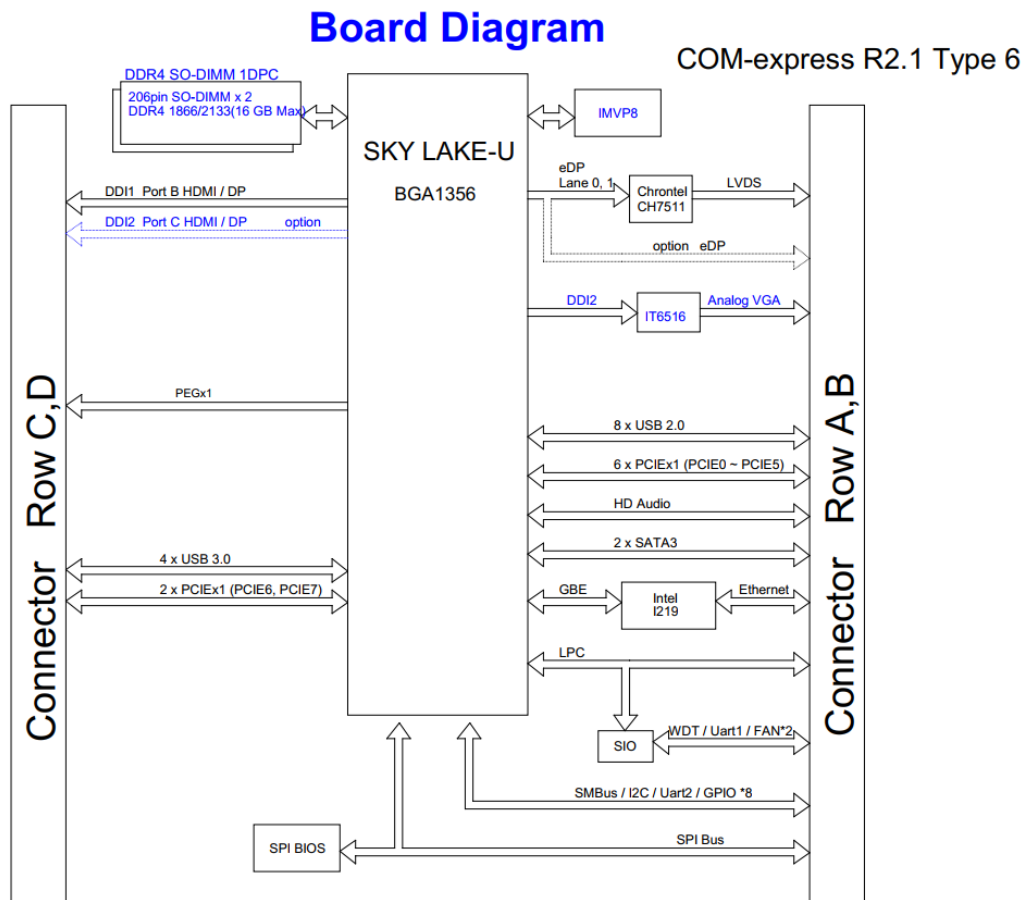

PCIe #0-3				PCIe #4-7			
x4				x4			
x4				x2		x2	
x4				x2		x1	x1
x4				x1	x1	x1	x1
x2		x2		x2		x2	
x2		x2		x1	x1	x1	
x1	x1	x1	x1	x1			
* The 3rd SATA (SATA Port2) can be supported on Core i7/i5/i3 platform by using PCIe Port7.							

### 1.3 产品料号

Model	Part Number	Specification
ECM-SKY6U2	8.ZRT.80-6437-21-LFF	ECM-SKY6U2 VER 12 I7-6600U+双内存条插槽+默认显示 (DDI/VGA/LVDS) -散热器/工包 20PCS
	8.ZRT.80-6437-20-LEE	ECM-SKY6U2-04 VER 12 I7-6600U+单内存条插槽+默认显示 (DDI/VGA/LVDS) -散热器/工包 20PCS
	8.ZRT.80-6437-02-LFF	ECM-SKY6U2 VER 11 I5-6300U+双内存条插槽+默认显示 (DDI/VGA/LVDS) -散热器/工包 20PCS
	8.ZRT.80-6437-03-LFF	ECM-SKY6U2 VER 10 I3-6100U+单内存条插槽+IT872E+I219+COM EXPRESS+散热器-工包 20PCS
	8.ZRT.80-6437-22-LEE	ECM-SKY6U2-05,V1.2,I3-6100U,单内存条插槽,散热器,LVDS,6U200F20,包装 20PCS
	8.ZRT.80-6437-18-LEF	ECM-SKY6U2-03 VER 12 I3-6100U+双内存条插槽+默认显示 (DDI/VGA/LVDS) -散热器/工包 20PCS

## 1.4 产品照片

### 1.4.1 eDP

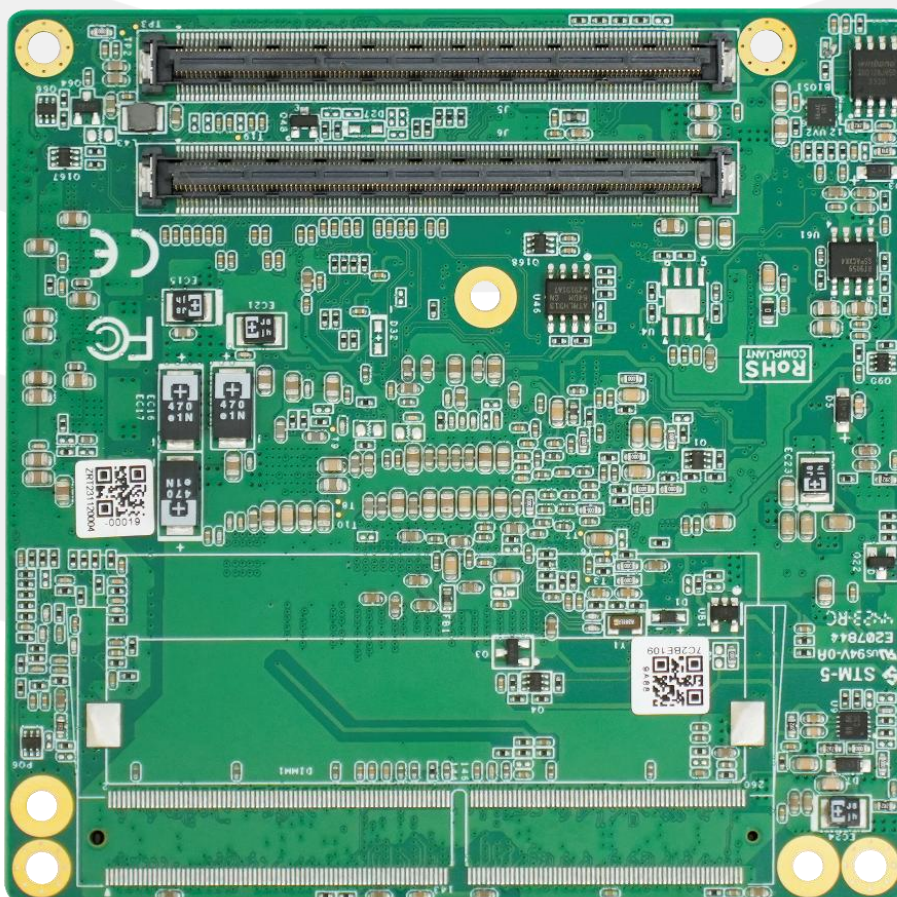
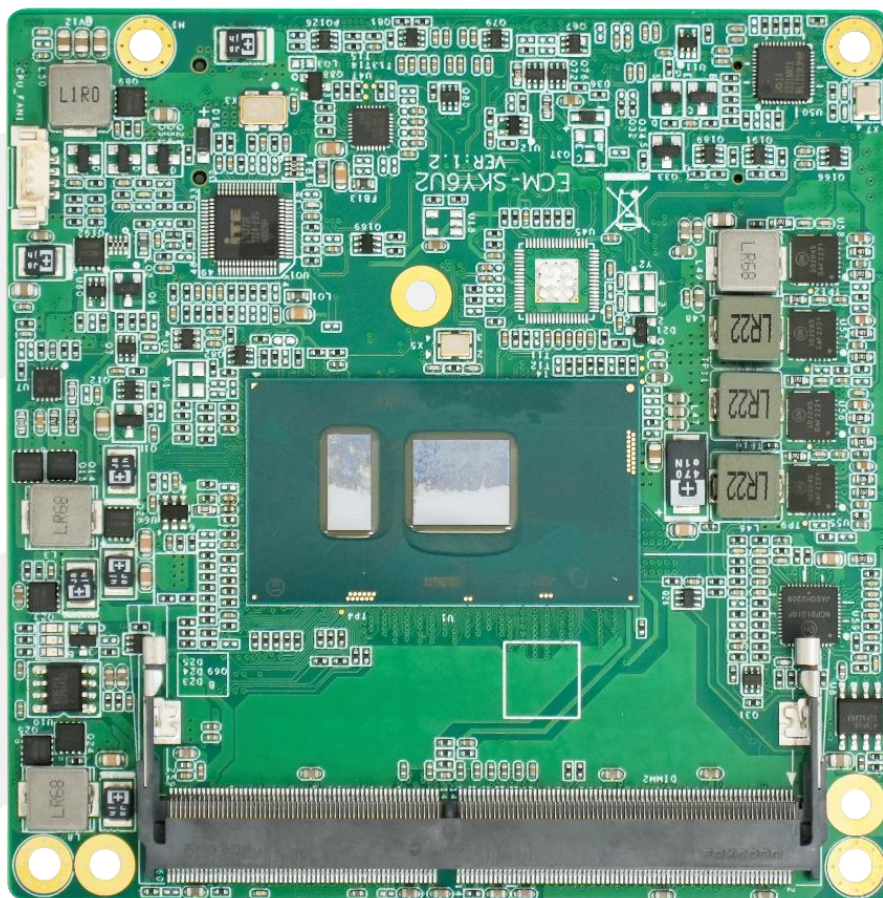

1.4.2 LVDS

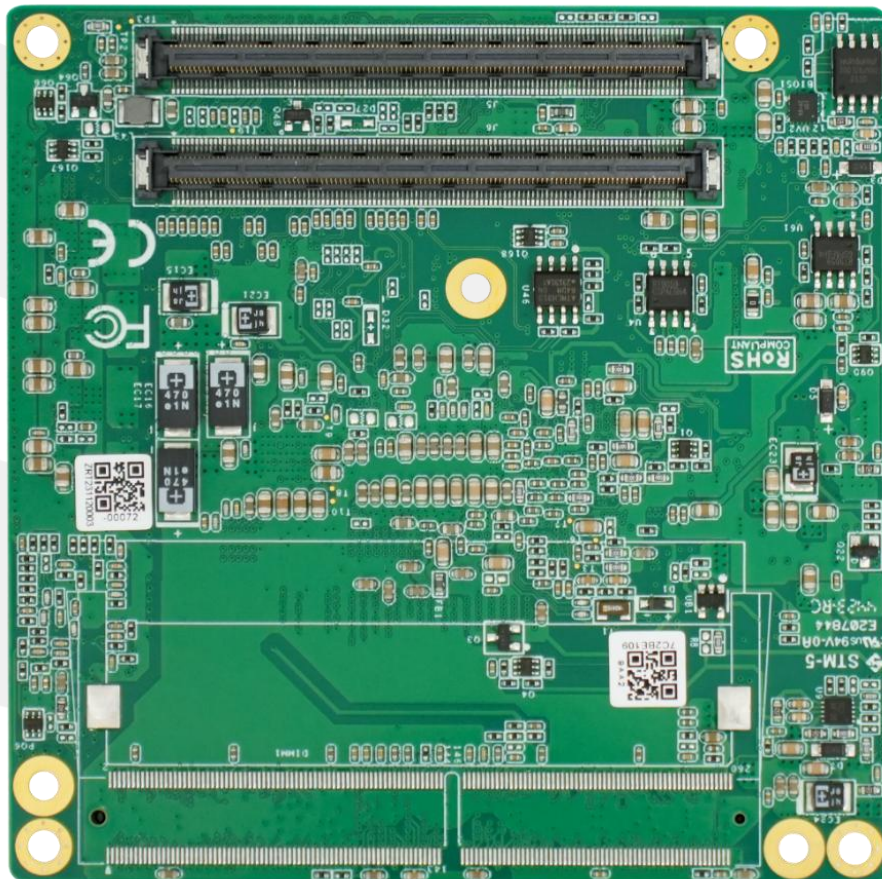
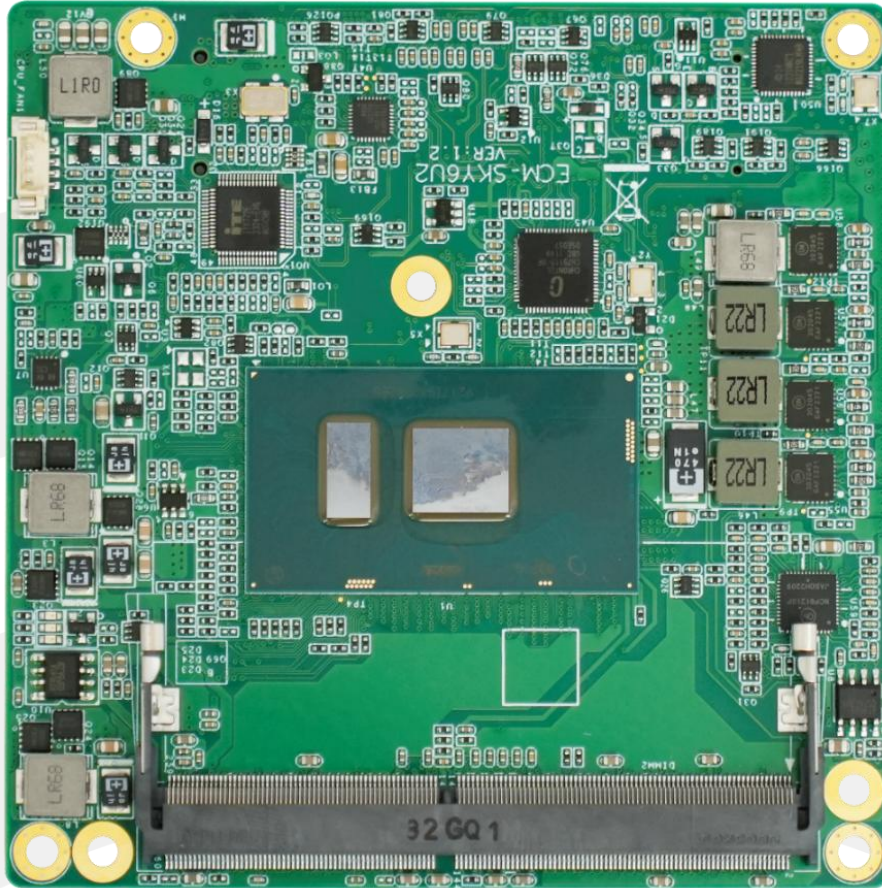

### 1.5 散热器

Part Number: 1.ZRT.48-6259-00-A00

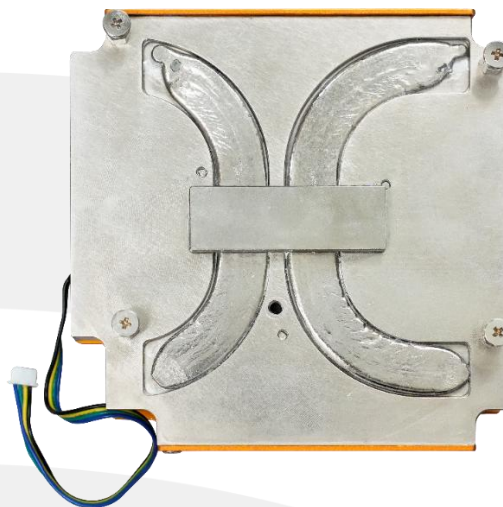

Part Number: 1.ZRT.48-6297-00-A00

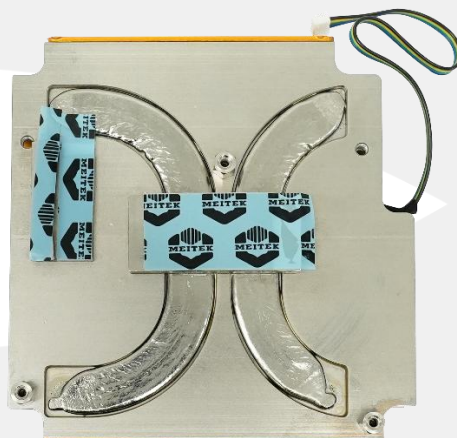

Part Number: 1.ZRT.48-6307-02-A00



Part Number: 1.ZRT.48-6307-01-A00

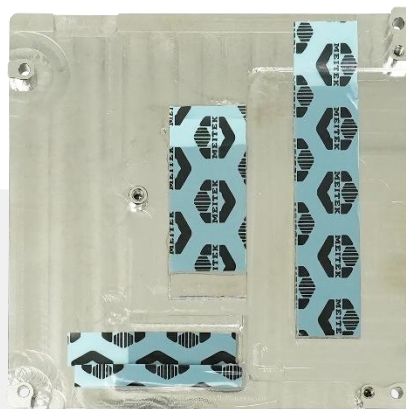

## 1.6 安装视频

[https://www.douyin.com/user/MS4wLjABAAAFV567Mcp9KjHrjFWngJgFG8h7XMSWsqH55hBlryutm?from\\_tab\\_name=main&modal\\_id=7429655415694052618](https://www.douyin.com/user/MS4wLjABAAAFV567Mcp9KjHrjFWngJgFG8h7XMSWsqH55hBlryutm?from_tab_name=main&modal_id=7429655415694052618)

## 第二章 安装说明

### 2.1 接口/尺寸图

安装设备时，请对照此示意图并详细阅读下面的说明，安装组件过程中必须小心，对于有些部件，如果安装不正确，设备将不能正常工作。

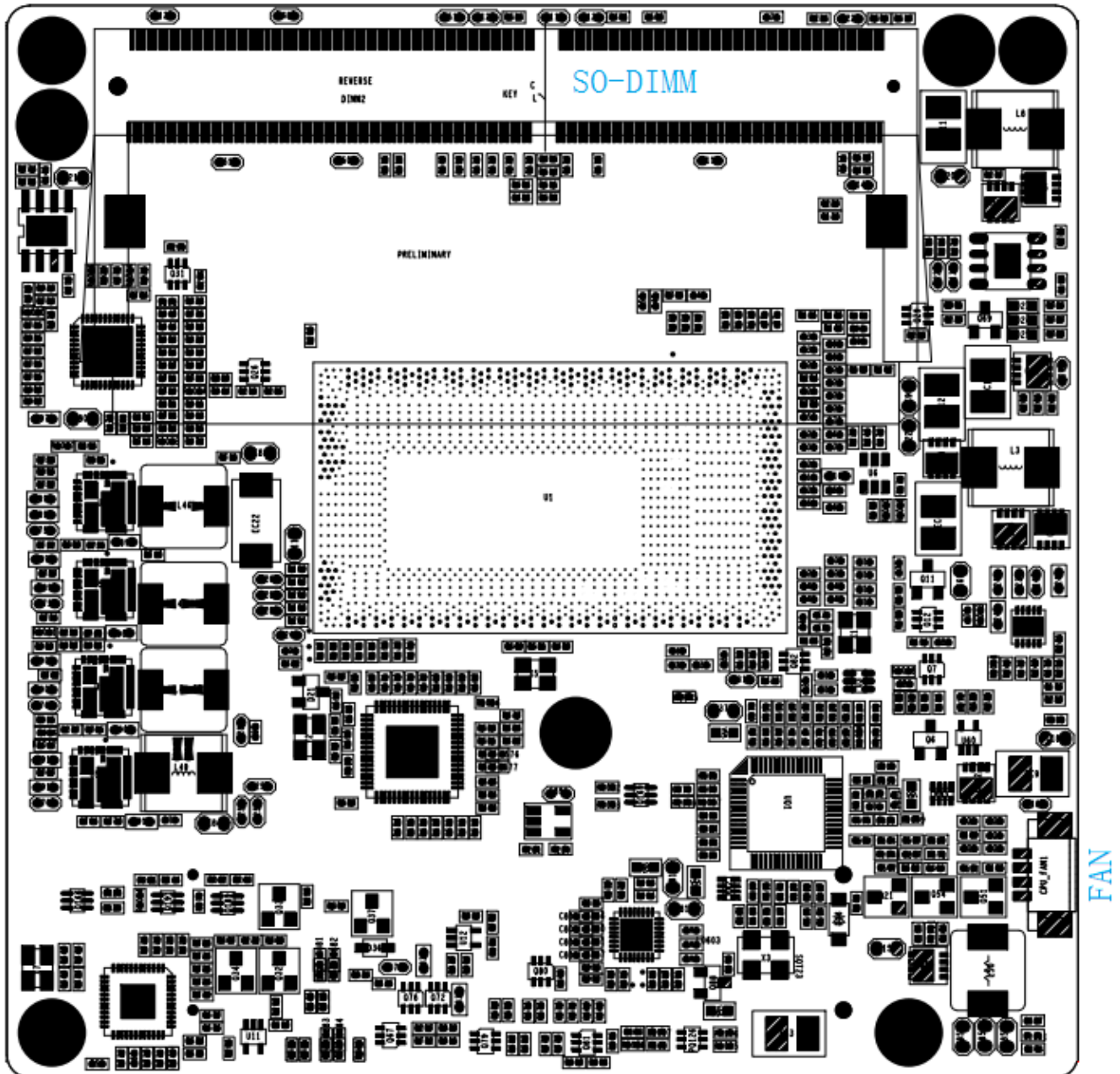

Interface Diagram

3D File: <https://drive.weixin.qq.com/s?k=AAAADgeKABAUTVg1x9>

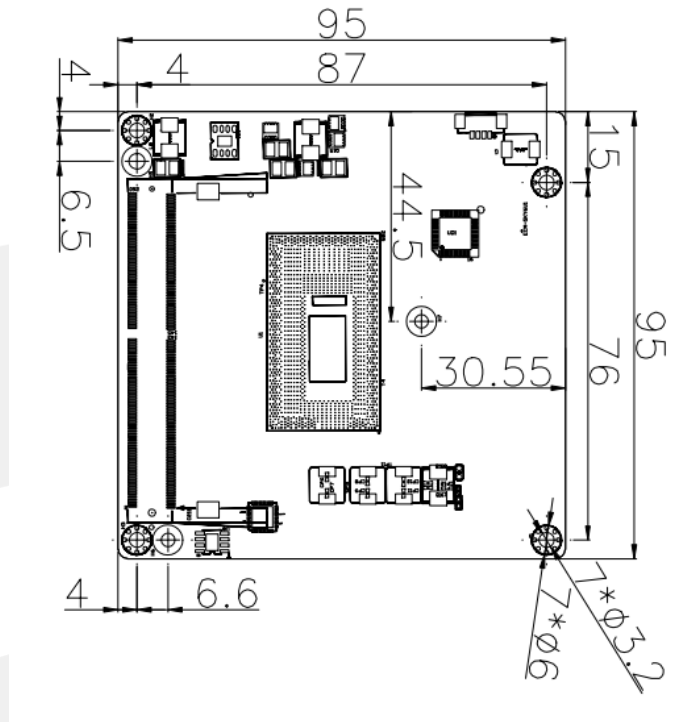

**Mechanical Drawing (TOP Side)**

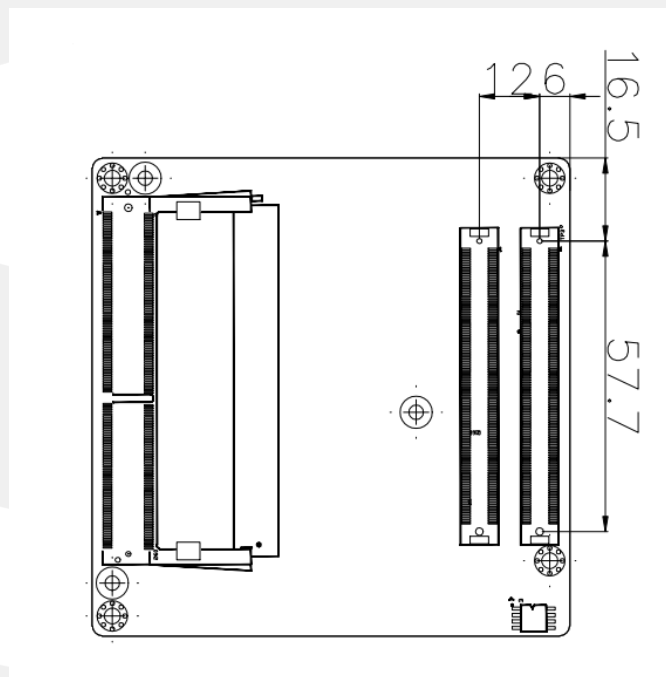

**Mechanical Drawing (Bottom Side)**

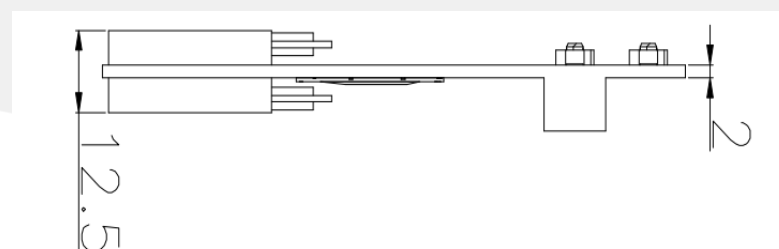

**Mechanical Drawing (Side view)**

## 2.2 硬件安装

**⚠ 注意：操作时，请戴上防静电手套，因为静电有可能会损坏部件。**

本主板关键元器件都是集成电路，而这些元件很容易因为遭受静电的影响而损坏。因此，请在正式安装主板之前，请先做好以下的准备：

1. 拿主板时手握板边，尽可能不触及元器件和插头插座的引脚。
2. 接触集成路元件(如 CPU、RAM 等)时，最好戴上防静电手环/手套。
3. 在集成电路元件未安装前，需将元件放在防静电垫或防静电袋内。
4. 在确认电源的开关处于断开位置后，再插上电源插头。

## 2.3 跳线功能设置

在进行硬件设备安装之前请按照您的需要对相应的跳线进行设置。

*提示：如何识别跳线、接口的第 1 针脚，观察插头插座旁边的文字标记，会用“1”或加粗的线条或三角符号表示；看看背面的焊盘，方型焊盘为第 1 针脚；所有跳线的针脚 1 旁都有 1 个白色箭头。*

## 2.4 接口引脚定义

Pin	Signal Name	Pin	Signal Name	Pin	Signal Name	Pin	Signal Name
A1	GND	B1	GND	C1	GND	D1	GND
A2	GBE0_MDI3-	B2	LINK#_ACTIVITY	C2	GND	D2	GND
A3	GBE0_MDI3+	B3	LPC_FRAME_N	C3	USB_SSRX0-	D3	USB_SSTX0-
A4	GBE0_LINK100#	B4	LPC_AD0	C4	USB_SSRX0+	D4	USB_SSTX0+
A5	GBE0_LINK1000#	B5	LPC_AD1	C5	GND	D5	GND
A6	GBE0_MDI2-	B6	LPC_AD2	C6	USB_SSRX1-	D6	USB_SSTX1-
A7	GBE0_MDI2+	B7	LPC_AD3	C7	USB_SSRX1+	D7	USB_SSTX1+
A8	NC	B8	NC	C8	GND	D8	GND
A9	GBE0_MDI1-	B9	NC	C9	USB_SSRX2-	D9	USB_SSTX2-
A10	GBE0_MDI1+	B10	LPC_CLK	C10	USB_SSRX2+	D10	USB_SSTX2+
A11	GND	B11	GND	C11	GND	D11	GND
A12	GBE0_MDI0-	B12	PWRBTN#	C12	USB_SSRX3-	D12	USB_SSTX3-
A13	GBE0_MDI0+	B13	SMBCLK	C13	USB_SSRX3+	D13	USB_SSTX3+
A14	NC	B14	SMBDATA	C14	GND	D14	GND
A15	SUS_S3#	B15	SMBALERT	C15	NC	D15	DDPB_CTRLCLK_AUX+
A16	SATA0_TX+	B16	SATA1_TX+	C16	NC	D16	DDPB_CTRLDATA_AUX-
A17	SATA0_TX-	B17	SATA1_TX-	C17	NC	D17	NC
A18	SUS_S4#	B18	NC(硬件可配置为 SUS_STAT-)	C18	NC	D18	NC
A19	SATA0_RX+	B19	SATA1_RX+	C19	PCIE_RX6+	D19	PCIE_TX6+

Pin	Signal Name	Pin	Signal Name	Pin	Signal Name	Pin	Signal Name
A20	SATA0_RX-	B20	SATA1_RX-	C20	PCIE_RX6-	D20	PCIE_TX6-
A21	GND	B21	GND	C21	GND	D21	GND
A22	NC(硬件可配置为SATA2)	B22	NC	C22	PCIE_RX7+	D22	PCIE_TX7+
A23	NC(硬件可配置为SATA2)	B23	NC	C23	PCIE_RX7-	D23	PCIE_TX7-
A24	SUS_S5#	B24	NC(硬件可配置为ATXPG)	C24	DDPB_HPD	D24	NC
A25	NC(硬件可配置为SATA2)	B25	NC	C25	NC	D25	NC
A26	NC(硬件可配置为SATA2)	B26	NC	C26	NC	D26	DDIB_TXP0
A27	NC(硬件可配置为BATLOW-)	B27	WDT	C27	NC	D27	DDIB_TXN0
A28	SATA_LED	B28	NC	C28	NC	D28	NC
A29	HDA_SYNC	B29	HDA_SDIN1	C29	NC	D29	DDIB_TXP1
A30	AA	B30	HDA_SDIN0	C30	NC	D30	DDIB_TXN1
A31	GND	B31	GND	C31	GND	D31	GND
A32	HDA_BIT_CLK	B32	SPK-	C32	DDPC_CTRLCLK_AUX+	D32	DDIB_TXP2
A33	HDA_SDOUT	B33	SML1_CLK	C33	DDPC_CTRLDATA_AUX-	D33	DDIB_TXN2
A34	NC	B34	SML1_DATA	C34	DDPC_DDC_AUX_SEL	D34	DDPB_DDC_AUX_SEL
A35	THRMTRIP#	B35	CME_THRM	C35	NC	D35	NC
A36	USB6-	B36	USB7-	C36	NC	D36	DDIB_TXP3
A37	USB6+	B37	USB7+	C37	NC	D37	DDIB_TXN3
A38	USB_OCN3	B38	USB_OCN2	C38	NC	D38	NC
A39	USB4-	B39	USB5-	C39	NC	D39	DDIC_C_TXP0
A40	USB4+	B40	USB5+	C40	NC	D40	DDIC_C_TXN0
A41	GND	B41	GND	C41	GND	D41	GND
A42	USB2-	B42	USB3-	C42	NC	D42	DDIC_C_TXP1
A43	USB2+	B43	USB3+	C43	NC	D43	DDIC_C_TXN1
A44	USB_OCN1	B44	USB_OCN0	C44	NC	D44	DDPC_HPD
A45	USB0-	B45	USB1-	C45	NC	D45	NC
A46	USB0+	B46	USB1+	C46	NC	D46	DDIC_TXP2
A47	VCC_RTC	B47	NC(硬件可配置为PLRST)	C47	NC	D47	DDIC_TXN2
A48	NC(硬件可配置为PLRST)	B48	EXCD1_CPPE_N	C48	NC	D48	NC
A49	EXCD0_CPPE_N	B49	SYS_RESET#	C49	NC	D49	DDIC_TXP3
A50	LPC_SERIRQ	B50	CB_RESET#	C50	NC	D50	DDIC_TXN3
A51	GND	B51	GND	C51	GND	D51	GND

Pin	Signal Name	Pin	Signal Name	Pin	Signal Name	Pin	Signal Name
A52	PCIE_TX5+	B52	PCIE_RX5+	C52	PEG_RX0+	D52	PEG_TX0+
A53	PCIE_TX5-	B53	PCIE_RX5-	C53	PEG_RX0-	D53	PEG_TX0-
A54	GP_DO17	B54	GP_DI6	C54	GND	D54	NC
A55	PCIE_TX4+	B55	PCIE_RX4+	C55	NC	D55	NC
A56	PCIE_TX4-	B56	PCIE_RX4-	C56	NC	D56	NC
A57	GND	B57	GP_DI7	C57	NC	D57	NC
A58	PCIE_TX3+	B58	PCIE_RX3+	C58	NC	D58	NC
A59	PCIE_TX3-	B59	PCIE_RX3-	C59	NC	D59	NC
A60	GND	B60	GND	C60	GND	D60	GND
A61	PCIE_TX2+	B61	PCIE_RX2+	C61	NC	D61	NC
A62	PCIE_TX2-	B62	PCIE_RX2-	C62	NC	D62	NC
A63	GPI1	B63	GP_DI8	C63	NC	D63	NC
A64	PCIE_TX1+	B64	PCIE_RX1+	C64	NC	D64	NC
A65	PCIE_TX1-	B65	PCIE_RX1-	C65	NC	D65	NC
A66	GND	B66	WAKE0#	C66	NC	D66	NC
A67	GP_DO19	B67	NC	C67	NC	D67	GND
A68	PCIE_TX0+	B68	PCIE_RX0+	C68	NC	D68	NC
A69	PCIE_TX0-	B69	PCIE_RX0-	C69	NC	D69	NC
A70	GND	B70	GND	C70	GND	D70	GND
A71	LVDS_A0+/eD P_TX2+	B71	LVDS_B0+	C71	NC	D71	NC
A72	LVDS_A0- /eDP_TX2-	B72	LVDS_B0-	C72	NC	D72	NC
A73	LVDS_A1+/eD P_TX1+	B73	LVDS_B1+	C73	GND	D73	GND
A74	LVDS_A1- /eDP_TX1-	B74	LVDS_B1-	C74	NC	D74	NC
A75	LVDS_A2+/eD P_TX0+	B75	LVDS_B2+	C75	NC	D75	NC
A76	LVDS_A2- /eDP_TX0-	B76	LVDS_B2-	C76	GND	D76	GND
A77	LVDS_VDD_EN /eDP_VDD_EN	B77	LVDS_B3+	C77	NC	D77	NC
A78	LVDS_A3+	B78	LVDS_B3-	C78	NC	D78	NC
A79	LVDS_A3-	B79	LVDS_BKLT_E N/eDP_BLK_T_E N	C79	NC	D79	NC
A80	GND	B80	GND	C80	GND	D80	GND
A81	LVDS_A_CK+/ eDP_TX3+	B81	LVDS_B_CK+	C81	NC	D81	NC
A82	LVDS_A_CK- /eDP_TX3-	B82	LVDS_B_CK-	C82	NC	D82	NC

Pin	Signal Name	Pin	Signal Name	Pin	Signal Name	Pin	Signal Name
A83	LVDS_I2C_CK/ eDP_AUX+	B83	LVDS_BKLT_CTL RL/eDP_BLKT_ CTRL	C83	NC	D83	NC
A84	LVDS_I2C_DAT /eDP_AUX-	B84	5VSB_ATX	C84	GND	D84	GND
A85	GP_DO20	B85	5VSB_ATX	C85	NC	D85	NC
A86	NC	B86	5VSB_ATX	C86	NC	D86	NC
A87	EDP_HPDP	B87	5VSB_ATX	C87	GND	D87	GND
A88	PCIE0_CK_REF +	B88	NC	C88	NC	D88	NC
A89	PCIE0_CK_REF-	B89	VGA_RED	C89	NC	D89	NC
A90	GND	B90	GND	C90	GND	D90	GND
A91	3VSB(SPI_PO WER)	B91	VGA_GRN	C91	NC	D91	NC
A92	SPI_MISO	B92	VGA_BLU	C92	NC	D92	NC
A93	GP_DI5	B93	VGA_HSYNC	C93	GND	D93	GND
A94	SPI_CLK	B94	VGA_VSYNC	C94	NC	D94	NC
A95	SPI_MOSI	B95	VGA_I2C_CK	C95	NC	D95	NC
A96	TPM_PP	B96	VGA_I2C_DAT	C96	GND	D96	GND
A97	NC	B97	SPI_CS#	C97	NC	D97	NC
A98	UART_TXD	B98	NC	C98	NC	D98	NC
A99	UART_RXD	B99	NC	C99	NC	D99	NC
A100	GND	B100	GND	C100	GND	D100	GND
A101	CPU_TXD	B101	FAN_CTL2	C101	NC	D101	NC
A102	CPU_RXD	B102	FAN_TAC2	C102	NC	D102	NC
A103	NC	B103	CME_SLEEP_N	C103	GND	D103	GND
A104	VCC	B104	VCC	C104	VCC	D104	VCC
A105	VCC	B105	VCC	C105	VCC	D105	VCC
A106	VCC	B106	VCC	C106	VCC	D106	VCC
A107	VCC	B107	VCC	C107	VCC	D107	VCC
A108	VCC	B108	VCC	C108	VCC	D108	VCC
A109	VCC	B109	VCC	C109	VCC	D109	VCC
A110	GND	B110	GND	C110	GND	D110	GND

## 第三章 BIOS 程序设置

### AMI BIOS 刷新

BIOS 提供对硬件资源的底层驱动，是联系硬件和操作系统的桥梁。现在硬件和各种应用软件不断更新，当您的系统遇到问题时，例如系统不支持最新公布的 CPU 时，就需要升级您的 BIOS 了。

#### 注意：

1. 升级 BIOS 只在遇到问题，必要的时候进行。
2. 在升级过程中不要关闭电源或重新启动系统，这会使您的 BIOS 资料将被损坏，系统也可能不能启动。
3. 为防止意外发生，请您先备份当前的 BIOS 资料。

### AMI BIOS 描述

开机时，BIOS 会对主板上的硬件进行自我诊断，设定硬件时序参数等工作，最后才将系统控制权交给操作系统。如何正确的设定 BIOS 参数对系统是否稳定的工作及系统是否工作在最佳状态至关重要。

### 进入 BIOS 参数设置

电脑开机，在完成自我诊断后，屏幕上会显示出如下信息：Del->SETUP，此时您点击一下 Del 键，则 BIOS 在完成 IDE 等设备的侦测后会自动转入 SETUP 设置画面。

1. 打开系统电源或重新启动系统，显示器屏幕将出现自我测试的信息。
2. 当屏幕中间出现“Press<Del>to enter setup”提示时，按下<Del>键，就可以进入 BIOS 设定程序。
3. 以方向键移动至您要修改的选项，按下<Enter>键即可进入该选项的子画面。
4. 使用方向键及<Enter>键即可修改所选项目的值，按回车键选择 BIOS 选项并修改。
5. 任何时候按下<Esc>键即可回到上一画面。



**提示：**BIOS 参数属于系统关键信息，请勿随意设置，如需设置或者升级请联系我司售后支持，谢谢！

## Setup Utility User Interface

This document describes BIOS Setup Utility user interface.

### 3.1 Main Screen

The Main screen is the first screen that is displayed when the BIOS Setup is entered.

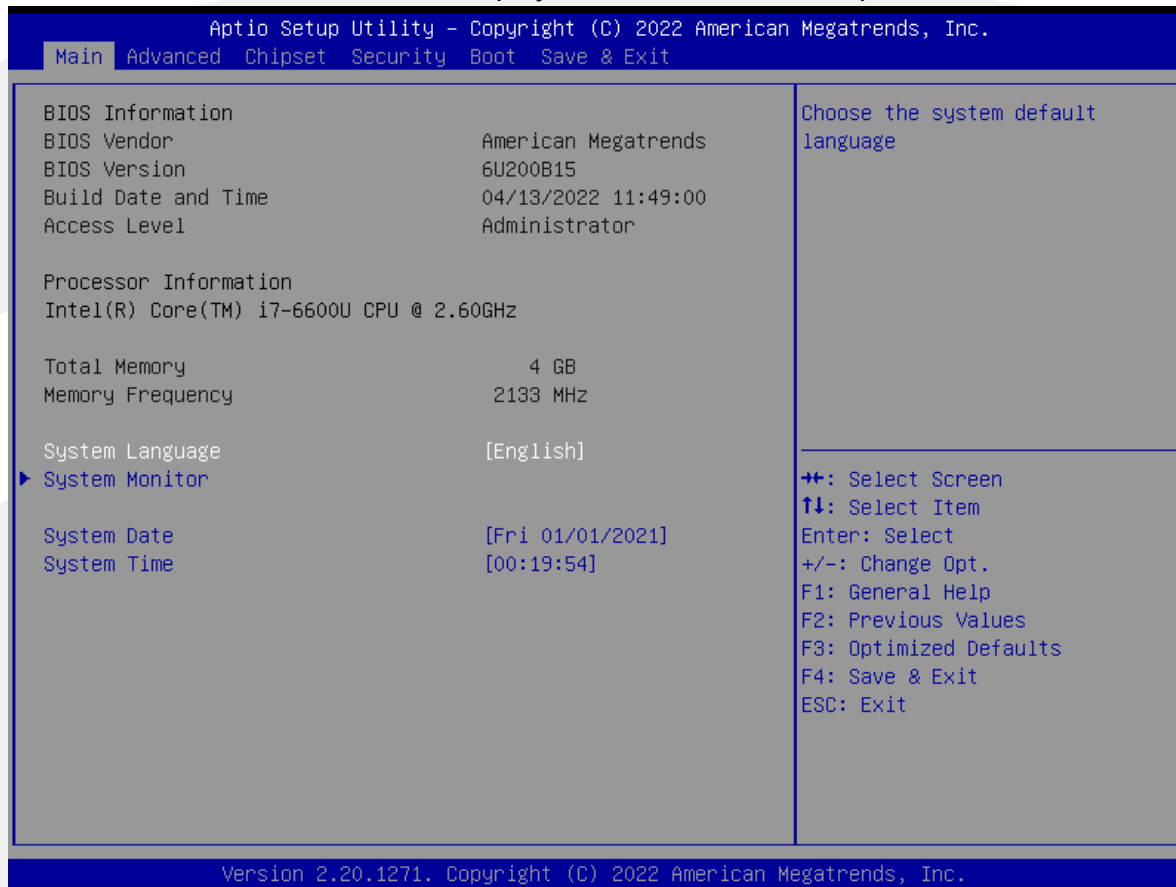

Setup Item	Options	Help Text	Comments
<b>BIOS Information</b>			
BIOS Vendor			Displays BIOS vendor .
Project Version			Displays the current BIOS version: Format: AAAABCC <b>AAAAA = Project name</b> <b>B = Customer number</b> <b>CC = BIOS revision</b>
Build Date and Time			Displays the current BIOS build date.
Access Level			Displays password level that setup is running in: Administrator or User. With no passwords set, Administrator is the default mode.

Setup Item	Options	Help Text	Comments
<b>Processor Information</b>			
CPU XXXXX			Displays the CPU Brand String installed in the system.
<b>Memory Information</b>			
Total Memory			Displays the total physical memory installed in the system, MB Unit.
Memory Frequency			Displays the Frequency of Memory.
System Language	English	Choose the system default language.	
System Monitor		Monitor hardware status.	
System Date	[Day of week MM/DD/YYYY]	Set and display the Date.	
System Time	[HH:MM:SS]	Set and display the Time.	

### 3.1.1 System Monitor

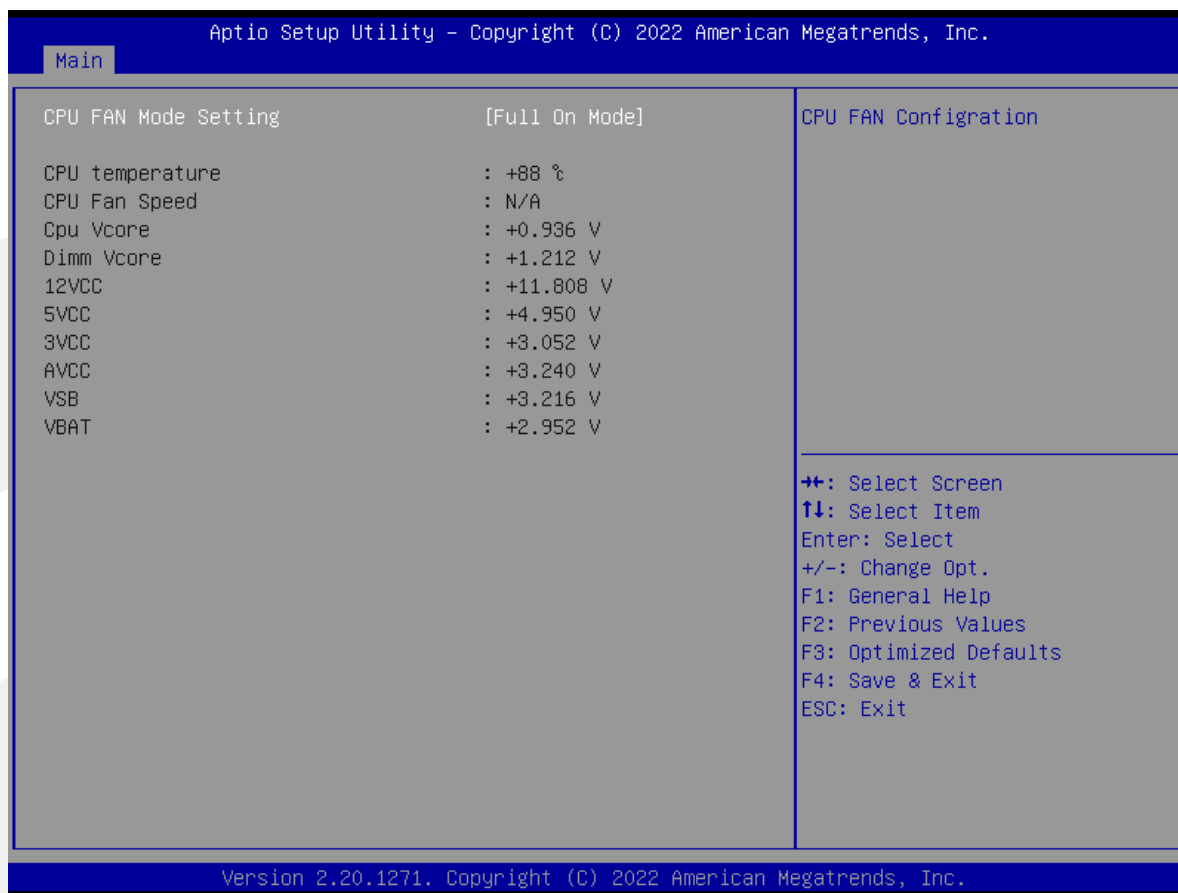

Setup Item	Options	Help Text	Comments
CPU FAN Mode Setting	Full on mode Automatic mode PWM Manually mode	CPU FAN Configuration.	
CPU temperature			Monitor hardware status.
CPU Fan Speed			
Cpu Vcore			
Dimm Vcore			
12VCC			
5VCC			
3VCC			
AVCC			
VSB			
VBAT			

### 3.2 Advanced Screen

The Advanced screen provides an access point to configure several options. On this screen, the user selects the option that is to be configured.

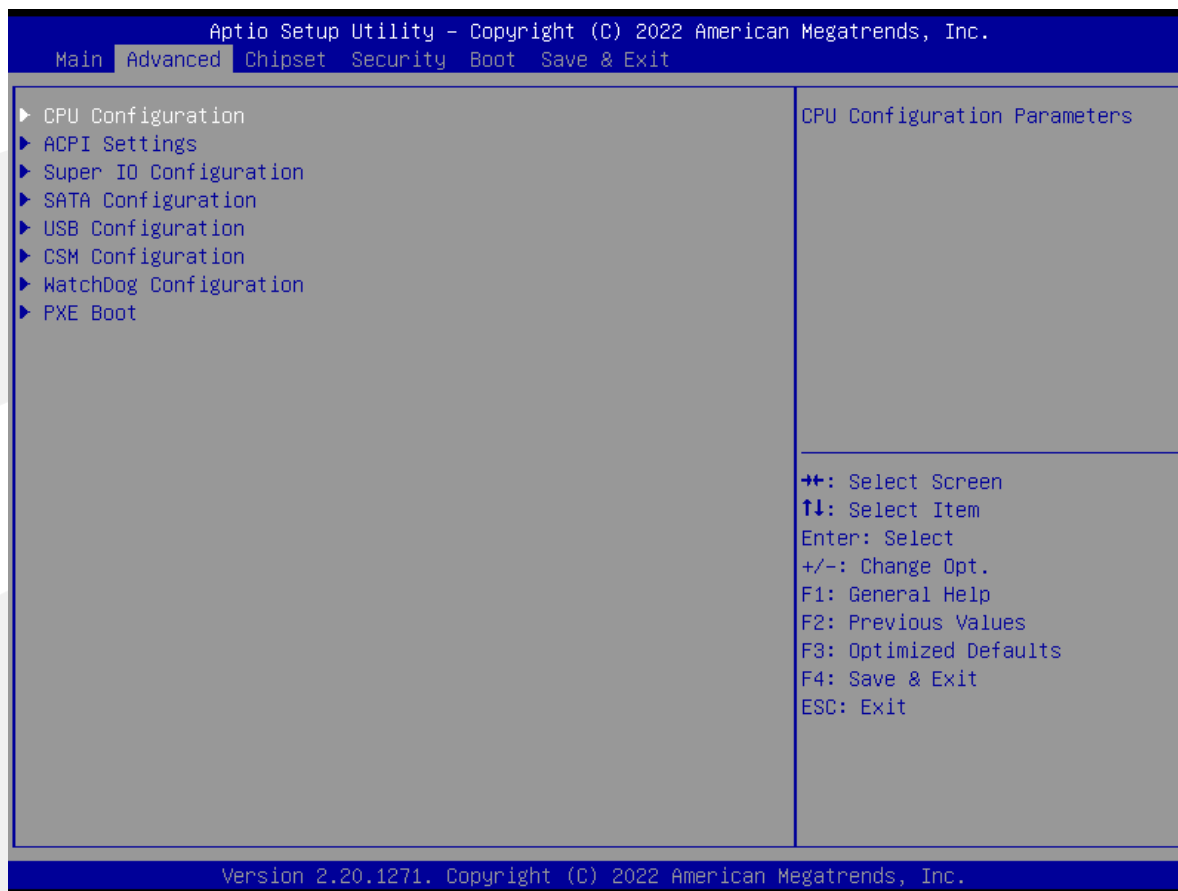

Setup Item	Options	Help Text	Comments
CPU Configuration		CPU Configuration Parameters.	
ACPI Settings		System ACPI Parameters.	
Super IO Configuration		System Super IO chip Parameters.	
SATA Configuration		SATA Devices Configuration.	
USB Configuration		USB Configuration Parameters.	
CSM Configuration		CSM configuration: Enable/Disable, Option ROM execution settings, etc.	
Watchdog configuration		Set System Watchdog Parameters.	
PXE Boot		PXE Boot Settings.	

### 3.2.1 CPU Configuration Screen

The CPU Configuration screen allows the user to view the processor information, and to enable or disable processor options. To access this screen from the Main screen, choose **Advanced > CPU Configuration**.

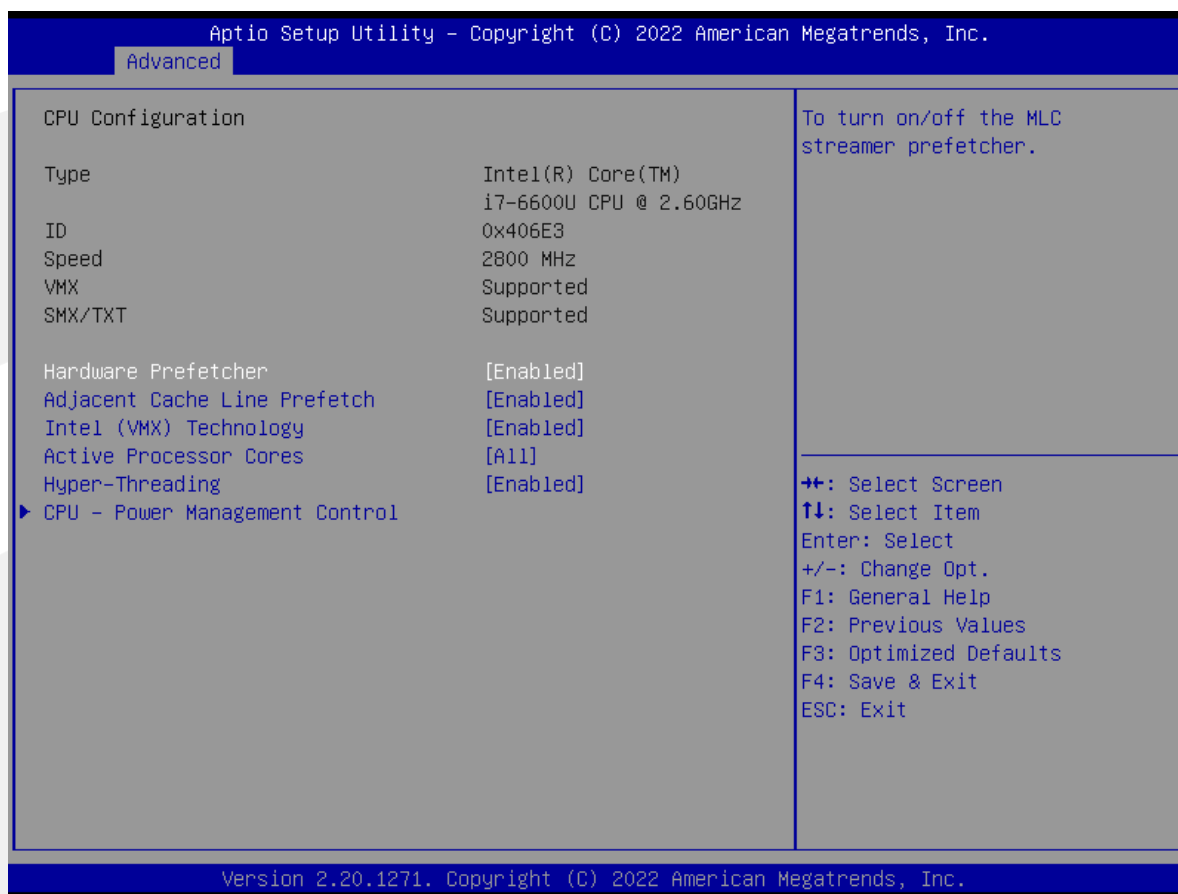

Setup Item	Options	Help Text	Comments
<b>CPU Configuration</b>			
Type			Displays the Processor Type.
ID			Displays the Processor ID.
Speed			Displays the Processor Speed.
VMX			VMX Supported or Not.
SMX/TXT			SMX/TXT Supported or Not.
Hardware Prefetcher	Enabled Disabled	To turn on/off the MLC streamer prefetcher.	
Adjacent Cache line Prefetch	Enabled Disabled	To turn on/off prefetching of adjacent cache lines.	
Intel(VMX) Technology	Enabled Disabled	When enabled, a VMM can utilize the additional hardware capabilities provided by Vanderpool technology.	
Active Processor Cores	All 1	Number of cores to enable in each processor package.	
Hyper-Threading	Enabled Disabled	Enabled for Windows XP and Linux (OS optimized for Hyper-Threading Technology) and Disabled for other OS (OS not optimized for Hyper-Threading Technology).	
CPU - Power Management Control		CPU - Power Management Control Options.	

### 3.2.1.1 CPU - Power Management Control

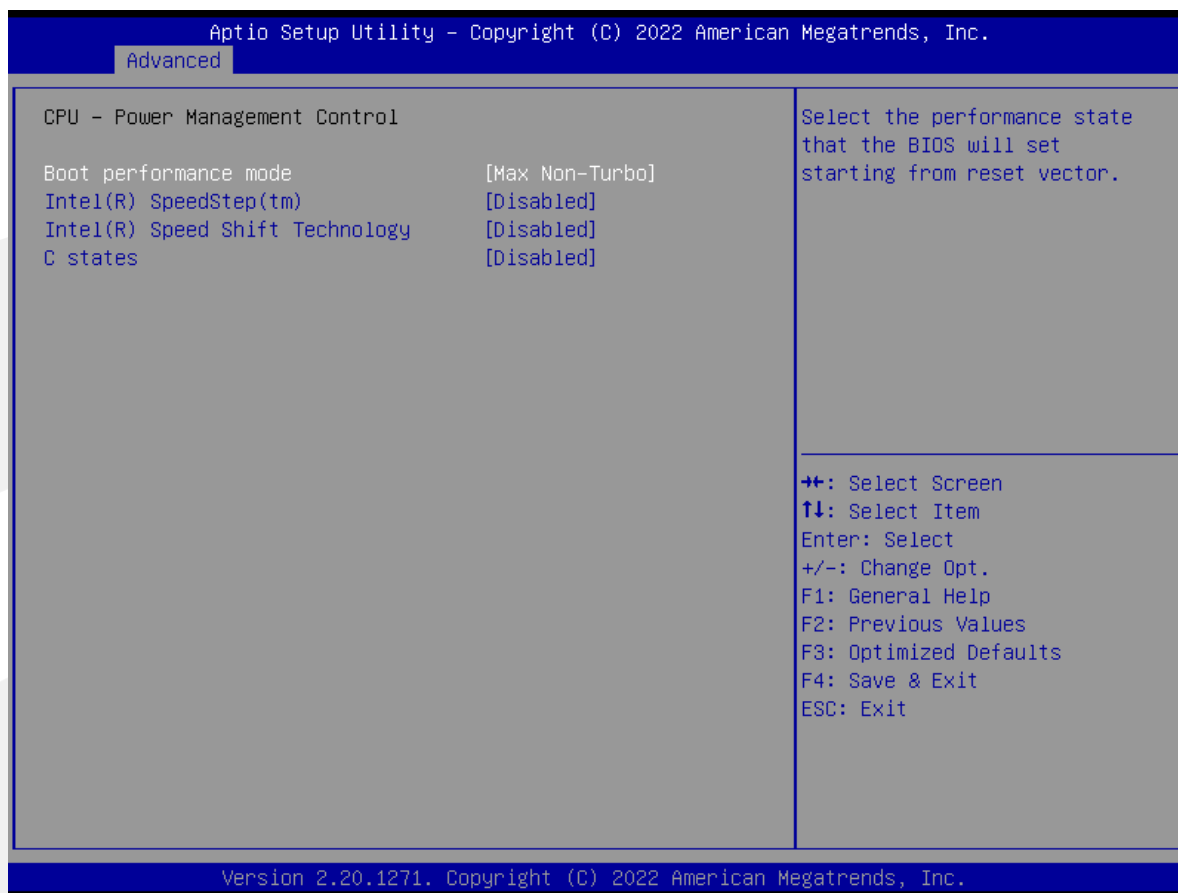

Setup Item	Options	Help Text	Comments
<b>CPU - Power Management Control</b>			
Boot performance mode	Max Battery Max Non-Turbo Turbo Performance	Select the performance state that the BIOS will set starting from reset vector.	
Intel(R) SpeedStep(tm)	Enabled Disabled	Allows more than two frequency ranges to be supported.	
Intel(R) Speed Shift Technology	Enabled Disabled	Enable/Disable Intel(R) Speed Shift Technology support. Enabling will expose the CPPC v2 interface to allow for hardware controlled P-states.	
C states	Enabled Disabled	Enable/Disable CPU Power Management. Allows CPU to go to C states when it's not 100% utilized.	

### 3.2.2 ACPI Settings Screen

The ACPI Settings screen allows the user to set the system ACPI parameters. To access this screen from the Main screen, choose **Advanced > ACPI Settings**.

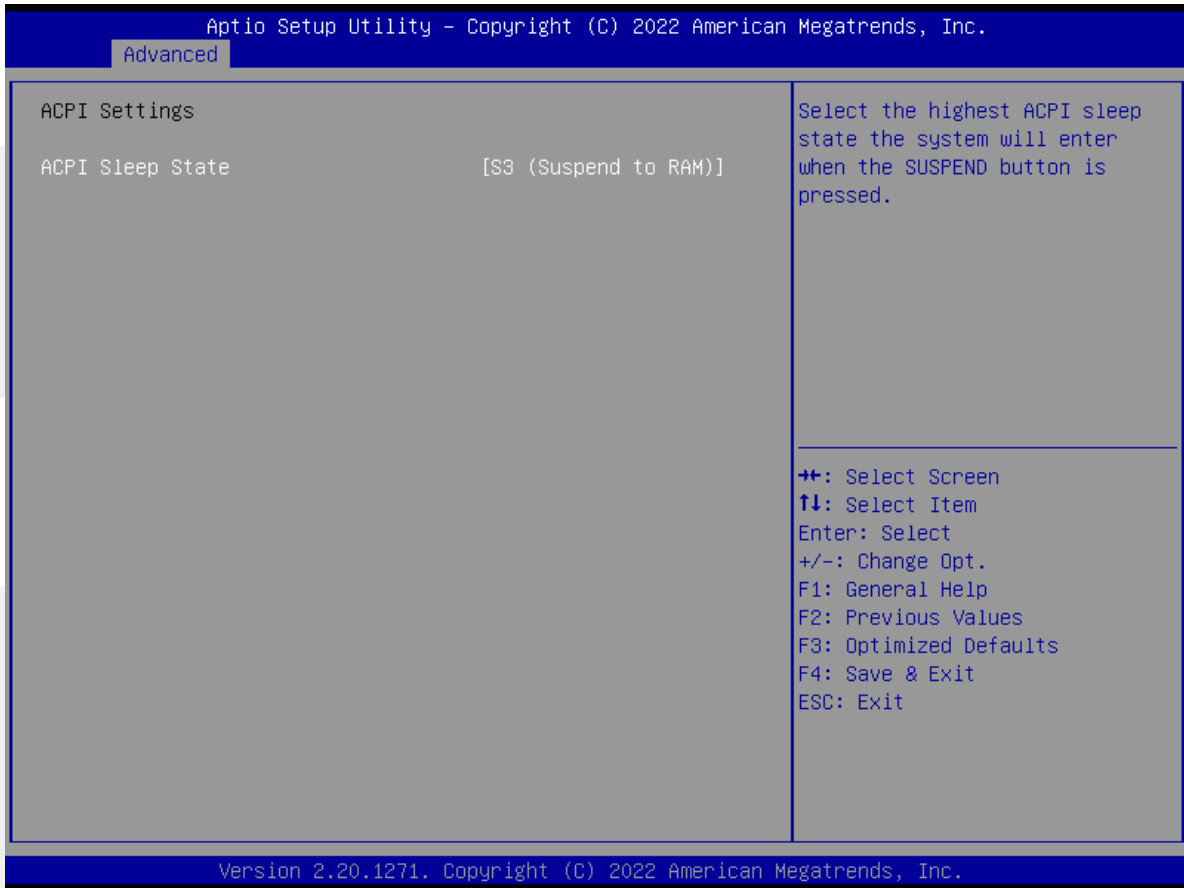

Setup Item	Options	Help Text	Comments
<b>ACPI Settings</b>			
ACPI Sleep State	Suspend Disabled S3 (Suspend to RAM)	Select the highest ACPI sleep state the system will enter when the SUSPEND button is pressed.	Sleep supported optionally.

### 3.2.3 Super IO Configuration

The SIO Configuration screen allows the user to view the super IO information, and to enable or disable super IO options. To access this screen from the Advanced screen, choose **Advanced > Super IO Configuration**.

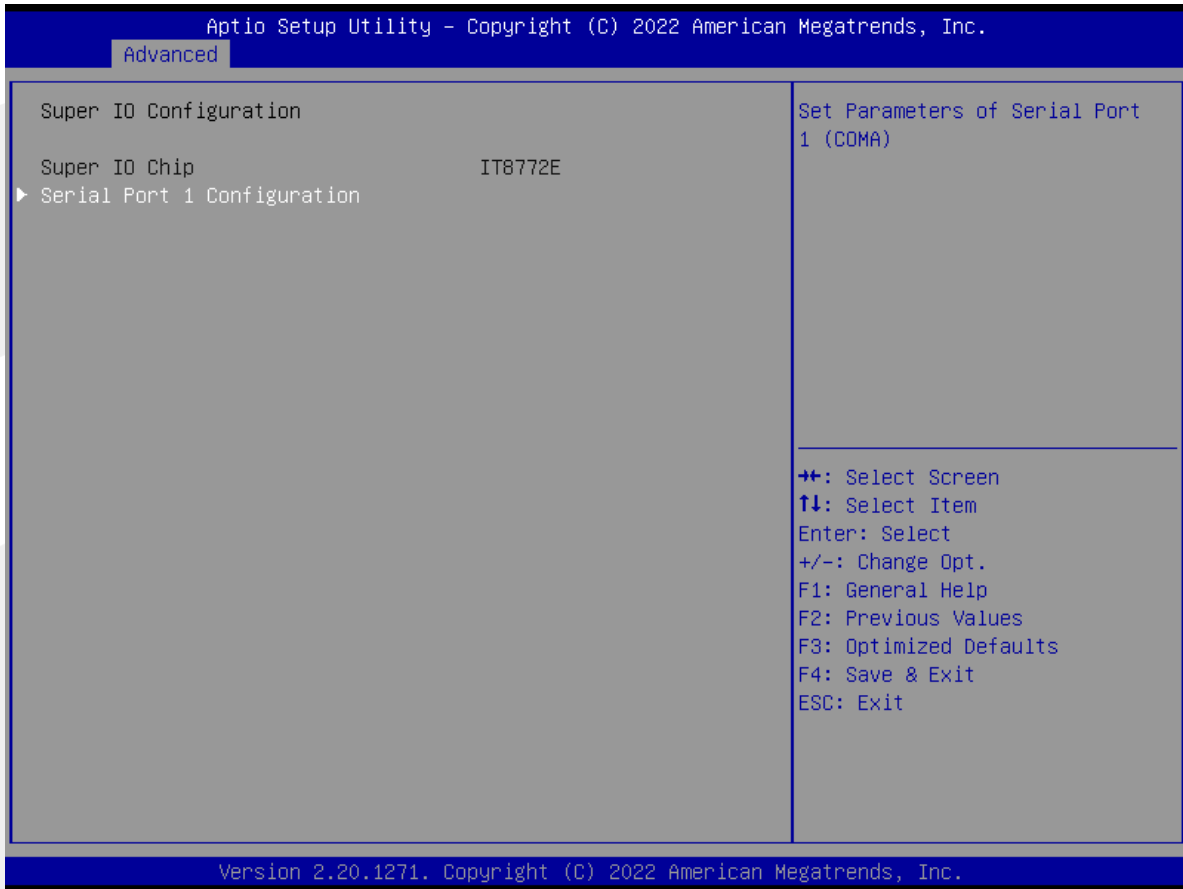

Setup Item	Options	Help Text	Comments
<b>Super IO Configuration</b>			
Super IO Chip			System Super IO Chip Parameters.
Serial Port 1 Configuration		Set Parameters of Serial Port 1(COMA).	

### 3.2.3.1 Serial Port 1 Configuration

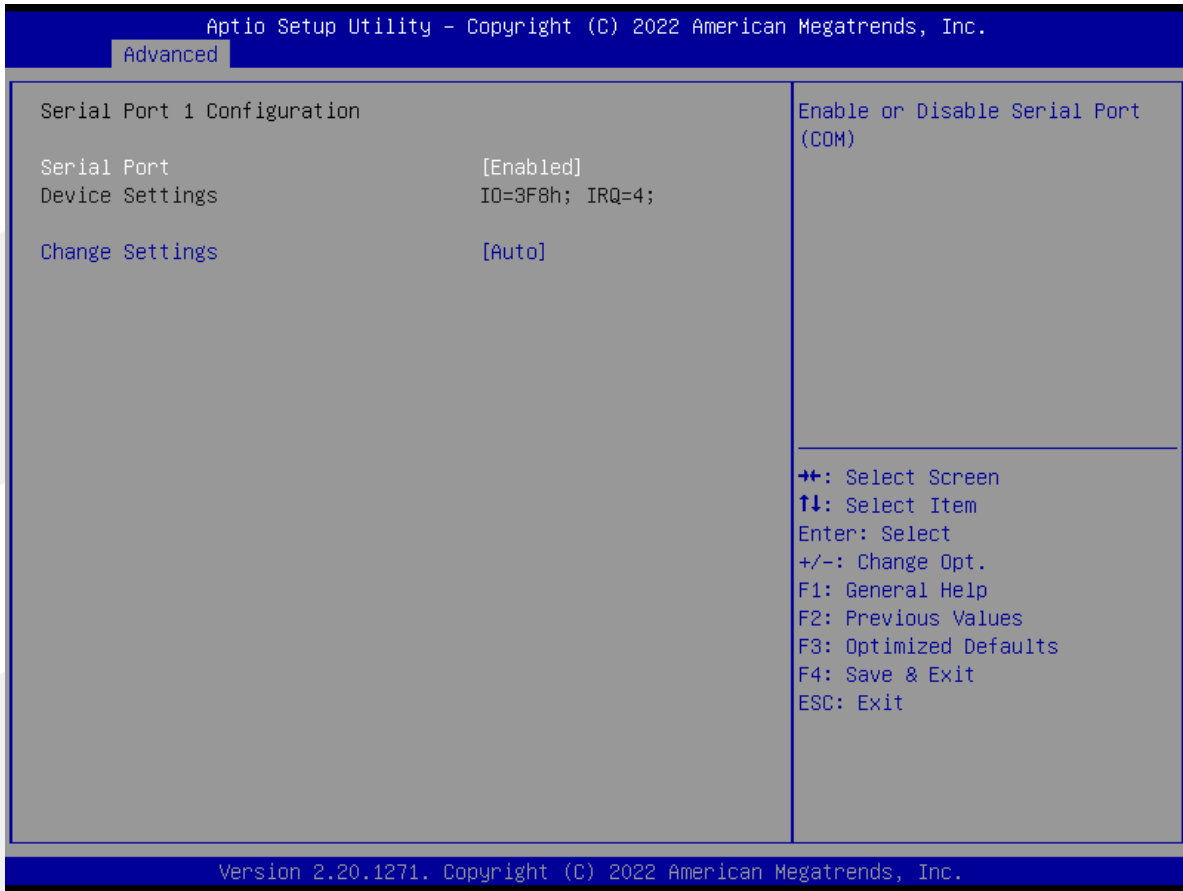

Setup Item	Options	Help Text	Comments
<b>Serial Port 1 Configuration</b>			
Serial Port	Enabled Disabled	Enable or Disable Serial Port (COM).	
Device Settings		Allows the user to change the device resource settings. New settings will be reflected on this setup page after system restarts.	
Change Settings	Auto IO=3F8h; IRQ=4 IO=3F8h; IRQ=3,4,5,6,7,9,10,11,12 IO=2F8h; IRQ=3,4,5,6,7,9,10,11,12 IO=3E8h; IRQ=3,4,5,6,7,9,10,11,12 IO=2E8h; IRQ=3,4,5,6,7,9,10,11,12	Select an optimal settings for Super IO Device.	

### 3.2.4 SATA Configuration

The SATA Configuration screen allows the user to view the SATA Configuration information, and to enable or disable options. To access this screen from the Main screen, choose **Advanced > SATA Configuration**.

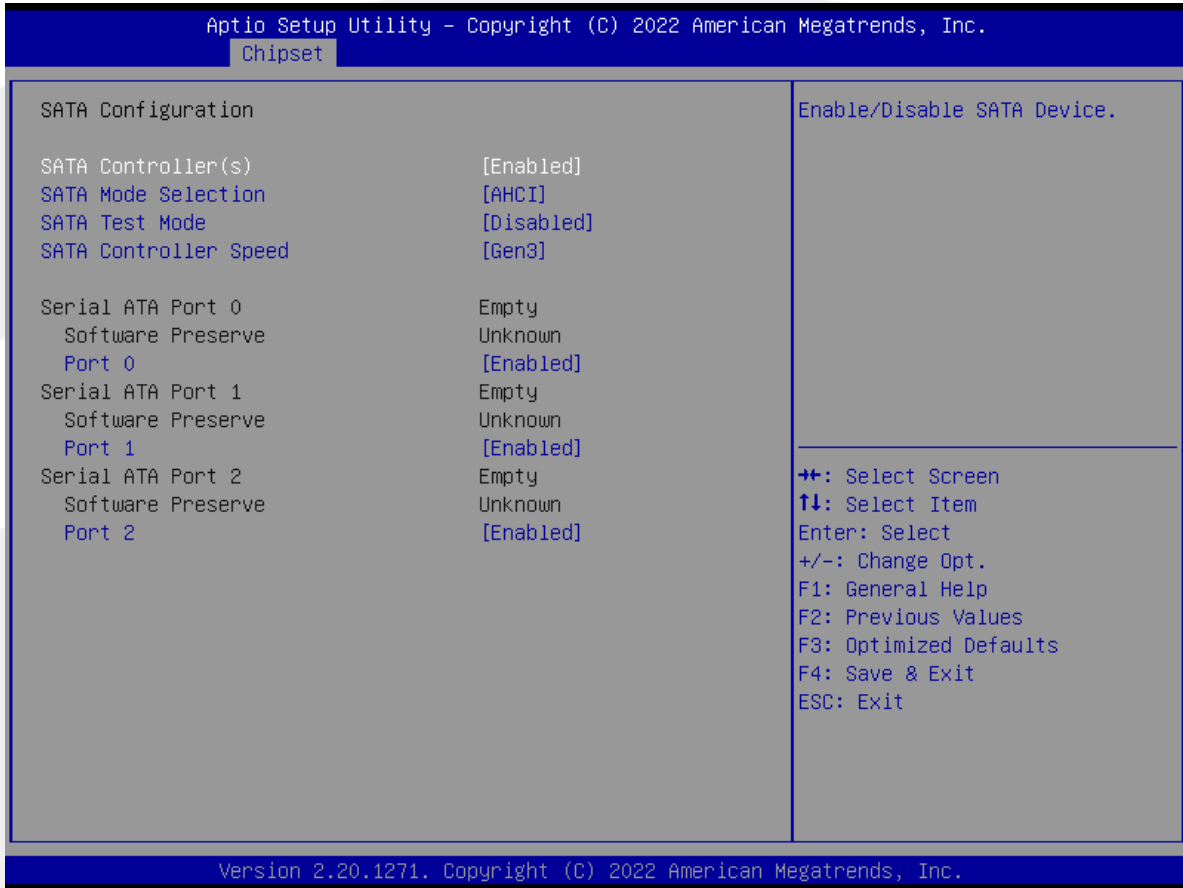

Setup Item	Options	Help Text	Comments
<b>SATA Configuration</b>			
SATA Configuration			
SATA Controller(s)	Enabled Disabled	Enable/Disable SATA Device.	
SATA Mode Selection	AHCI	Determines how SATA controller(s) operate.	
SATA Test Mode	Enabled Disabled	Test mode Enable/Disable(Loop Back).	
SATA Speed	Default Gen1 Gen2 Gen3	Indicates the maximum speed the SATA controller can support.	
Serial ATA Port 0			Show HDD information connected.
Serial ATA Port 1			
Serial ATA Port 2			

### 3.2.5 USB Configuration

The USB Configuration screen allows the user to view the USB Configuration information, and to enable or disable options. To access this screen from the Main screen, choose **Advanced > USB Configuration**.

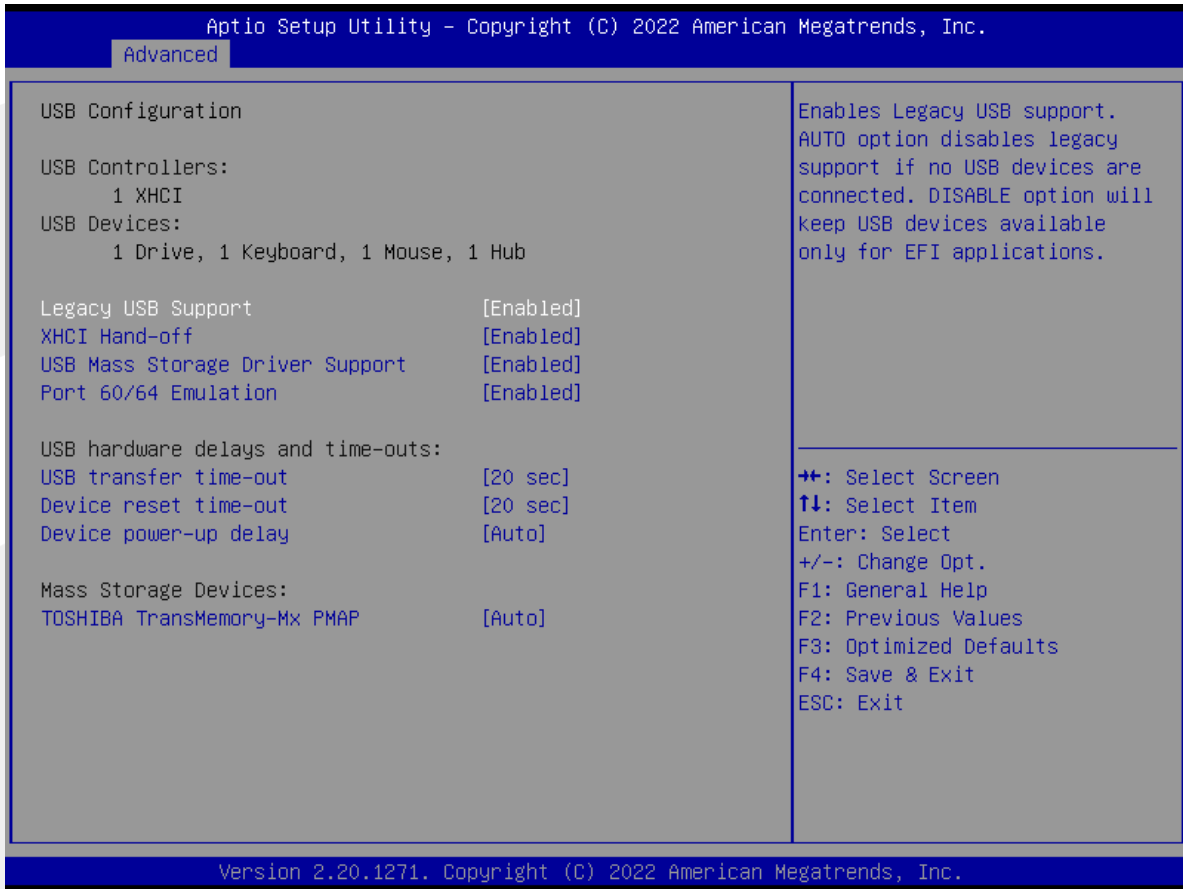

Setup Item	Options	Help Text	Comments
<b>USB Configuration</b>			
Legacy USB Support	Enabled Disabled	Enables Legacy USB support. AUTO option disables legacy support if no USB devices are connected. DISABLE option will keep USB devices available only for EFI applications.	
XHCI Hand-off	Enabled Disabled	This is a workaround for Oses without XHCI hand-off support. The XHCI ownership change should be claimed by XHCI driver.	
USB MASS Storage Driver Support	Enabled Disabled	Enable/Disable USB Mass Storage Driver Support.	
Port 60/64 Emulation	Enabled Disabled	Enables I/O port 60h/64h emulation support. This should be enabled for the complete USB keyboard legacy support for non-USB aware Oses.	
<b>USB hardware delays and time-outs</b>			
USB transfer time-out	1 sec 5 sec 10 sec 20 sec	The time-out value for Control, Bulk, and Interrupt transfers.	
Device reset time-out	10 sec 20 sec 30 sec 40 sec	USB mass storage device Start Unit command time-out.	
Device power-up delay	Auto Manual	Maximum time the device will take before it properly reports itself to the Host Controller. ' auto' uses default value: for a Root port it is 100ms,for a Hub port the delay is taken from Hub descriptor.	
<b>Mass Storage Device</b>			
TOSHIBA TransMemory-Mx PMAP	Auto		

### 3.2.6 CSM Configuration

The CSM Configuration screen allows the user to view the CSM information, and to enable or disable CSM options. To access this screen from the Main screen, choose **Advanced > CSM Configuration**.

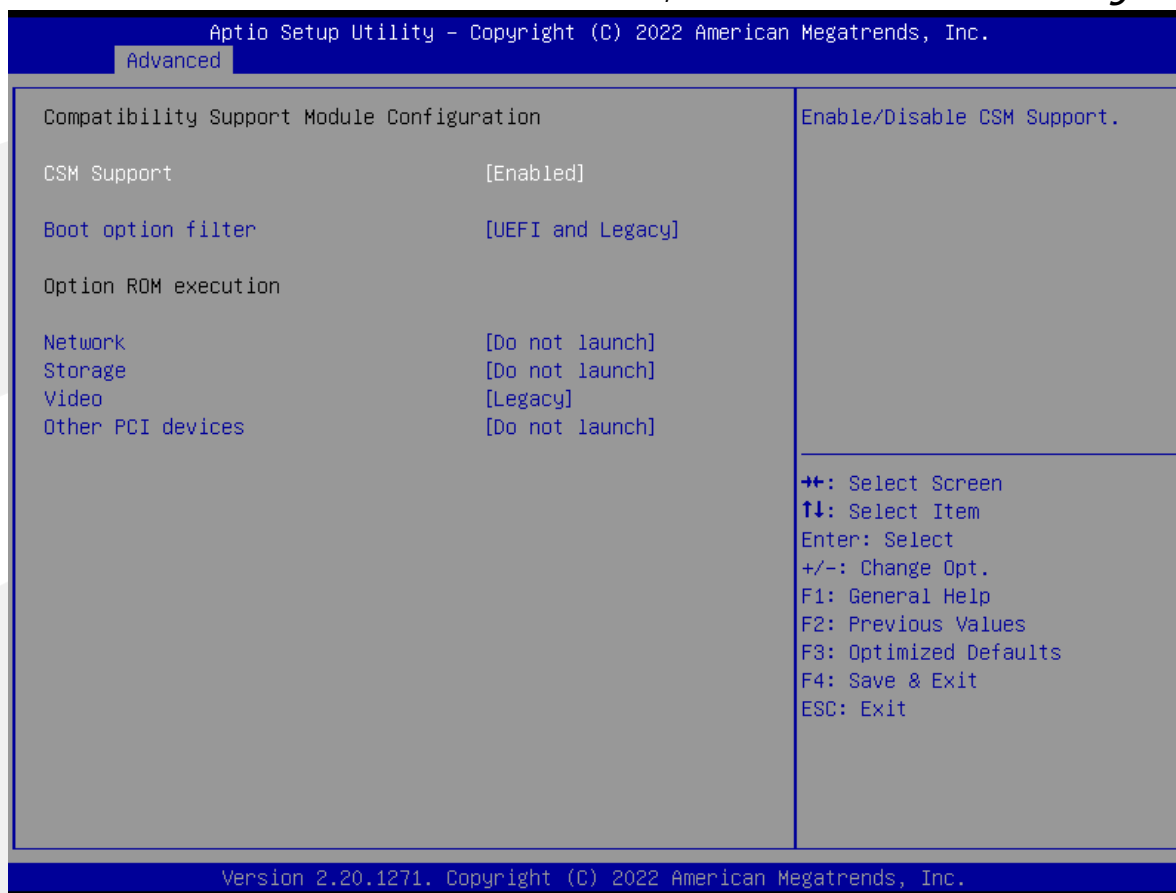

Setup Item	Options	Help Text	Comments
<b>Compatibility Support Module Configuration</b>			
CSM Support	Enabled Disabled	Enable/Disable CSM support.	
Boot option filter	UEFI and Legacy Legacy only UEFI only	This option control Legacy/UEFI ROMs priority.	
<b>Option ROM execution</b>			
Network	Do not launch UEFI Legacy	Control the execution of UEFI and Legacy PXE OpROM.	
Storage	Do not launch UEFI Legacy	Control the execution of UEFI and Legacy Storage OpROM.	
Video	Do not launch UEFI Legacy	Control the execution of UEFI and Legacy video OpROM.	
Other PCI devices	Do not launch UEFI Legacy	Determines OpROM execution policy for devices other than Network,Storage or video.	

### 3.2.7 Watchdog Configuration

The Watchdog Configuration screen allows the user to Set System WatchDog Parameters. To access this screen from the Main screen, choose **Advanced > Watchdog Configuration**.

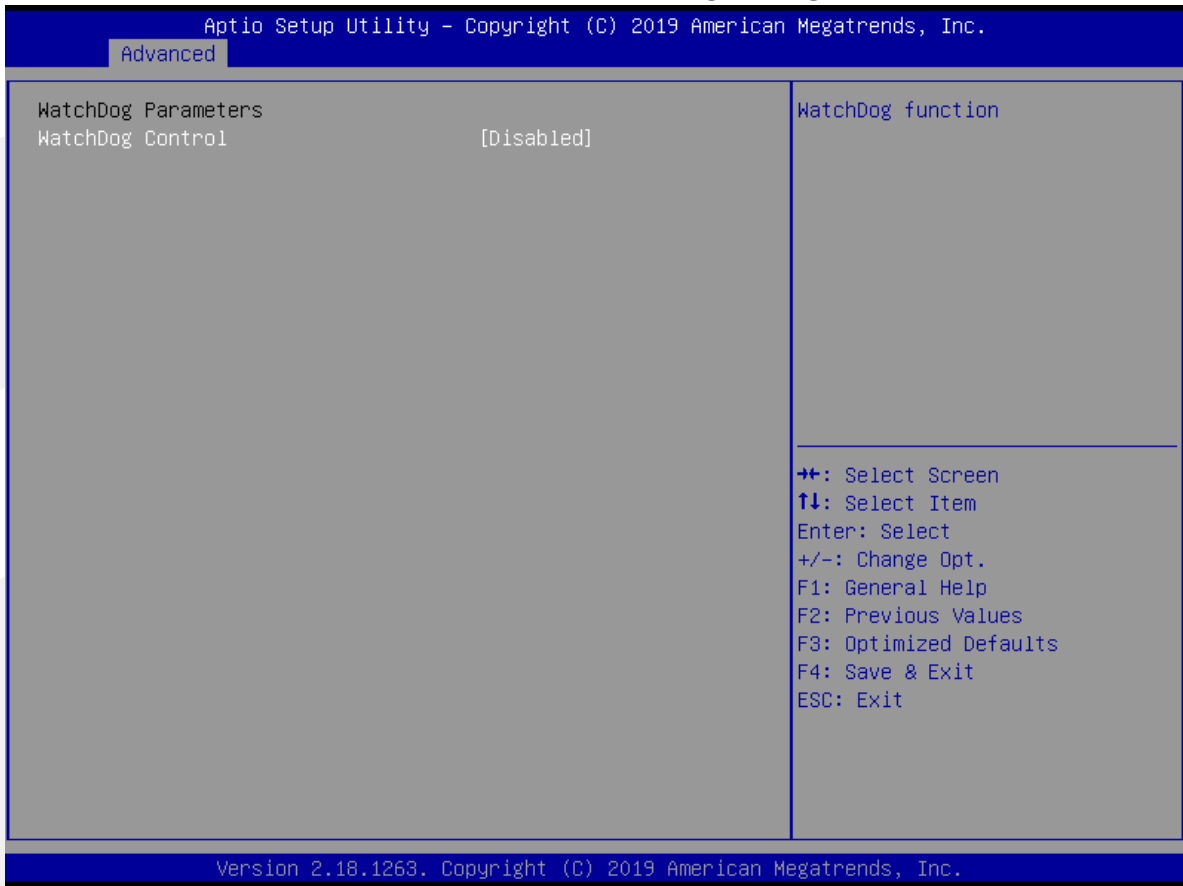

Setup Item	Options	Help Text	Comments
<b>Watchdog Configuration</b>			
WatchDog Control	Disabled Enabled		WatchDog function.
WatchDog Count Mode	Minute Second		WatchDog Count Mode Selection.
WatchDog TimeOut Value	1		Fill WatchDog TimeOut (0~255),0 means function disabled.

### 3.2.8 PXE Boot

The PXE Boot screen allows the user to Set PXE boot and GPIO options. To access this screen from the Main screen, choose **Advanced > PXE Boot**.

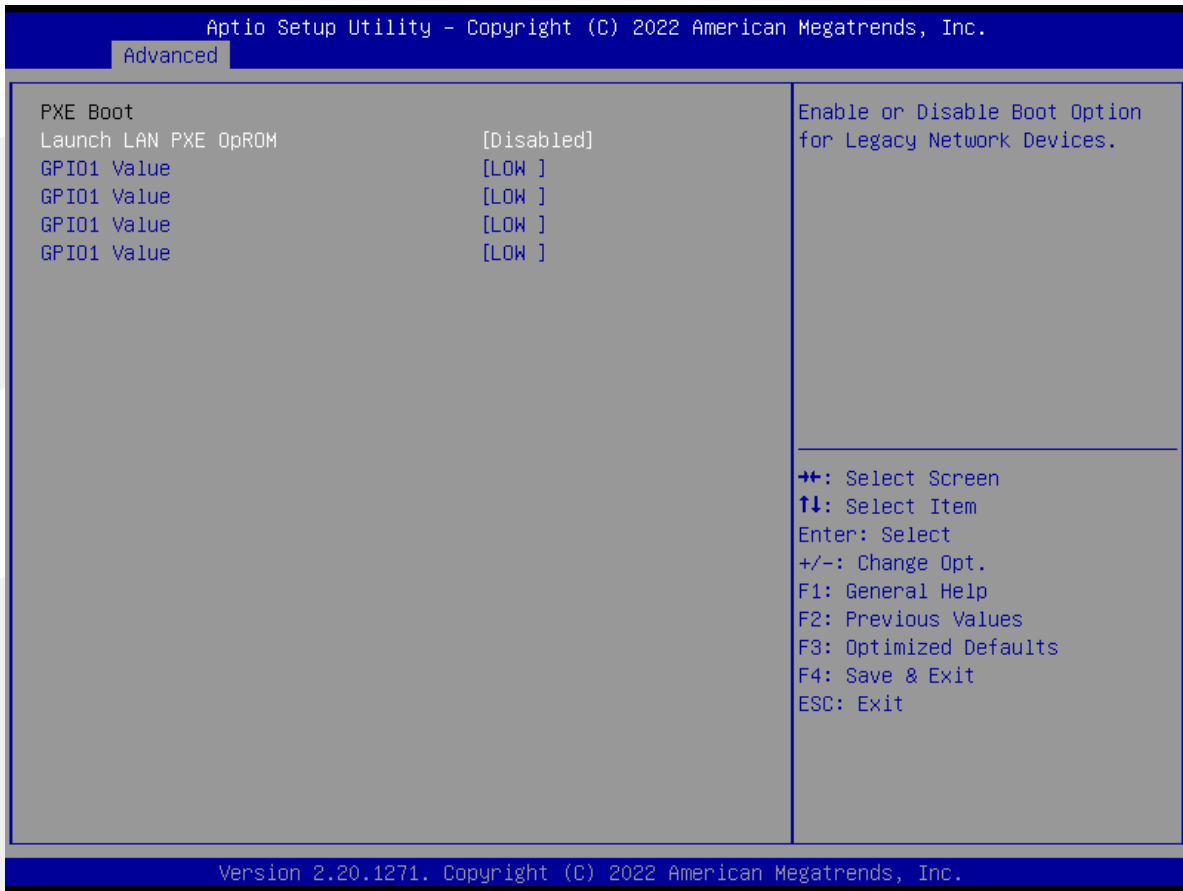

Setup Item	Options	Help Text	Comments
<b>PXE Boot</b>			
Launch LAN1 PXE OpROM	Disabled Enabled	Enable or Disable Boot option for Legacy Network Devices.	
GPIO1 Value	HIGH LOW	Set GPIO1 Value.	
GPIO1 Value	HIGH LOW		
GPIO1 Value	HIGH LOW		
GPIO1 Value	HIGH LOW		
GPIO1 Value	HIGH LOW		

### 3.3 Chipset Screen

The Chipset screen provides an access point to configure North Bridge and South Bridge.

To access this screen from the Main screen, press the right arrow until the Chipset screen is chosen.



Setup Item	Options	Help Text	Comments
<b>Chipset Screen</b>			
System Agent (SA) Configuration		System Agent (SA) Parameters.	
PCH-IO Configuration		PCH Parameters.	

### 3.3.1 System Agent (SA) Configuration

The North Bridge Screen allows user to set NB chipset configuration. To access this screen, form the Main screen, choose **Chipset-> System Agent (SA) Configuration**.



Setup Item	Options	Help Text	Comments
<b>System Agent (SA) Configuration</b>			
SA PCIe Code Version			Display the SA PCIE Code Version.
VT-d			Display the VT-D technology supported or not.
Graphics Configuration		Graphics Configuration.	

### 3.3.1.1 Graphics Configuration

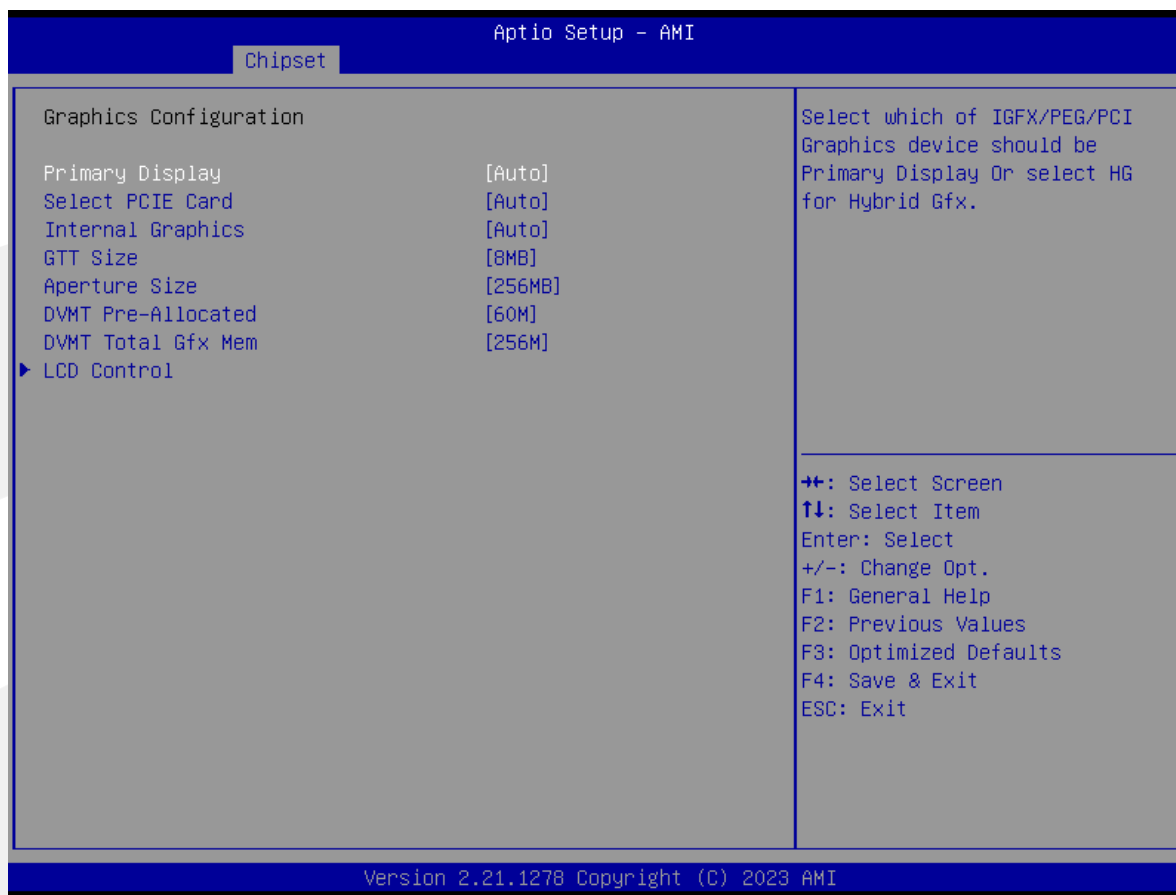

Setup Item	Options	Help Text	Comments
<b>Graphics Configuration</b>			
Primary Display	Auto IGFX PEG	Select which of IGFX/PEG/PCI Graphics device should be Primary Display Or select HG for Hybrid Gfx.	
Select PCIE Card	Auto		
Primary IGFX Boot Display	VBIOS Default DDI1 LFP(LVDS/eDP) EFP3(DDI3) DDI2 EFP4(DDI4)	Select the Video Device which will be activated during POST.\nThis has no effect if external graphics present.\nSecondary boot display selection will appear based on your selection.\nVGA modes will be supported only on primary display.	
Active LFP	No eDP eDP Port-A	Select the Active LFP Configuration. No LVDS:VBIOS does not enable LVDS. Int-LVDS:VBIOS enables LVDS driver by Integrated encoder. SDVO LVDS:VBIOS enables LVDS driver by SDVO encoder. eDP Port-A:LFP Driven by Int-DisplayPort encoder from Port-A.	
Internal Graphics	Auto Disabled Enabled	Keep IGFX enabled based on the setup options.	
GTT Size	2MB 4MB 8MB	Select the GTT Size.	
Aperture Size	128MB 256MB 512MB 1024MB 2048MB	Select the Aperture Size\n\nNote : Above 4GB MMIO BIOS assignment is automatically enabled when selecting 2048MB aperture. To use this feature, please disable CSM Support.	
DVMT Pre-Allocated	60M		
DVMT Total Gfx Mem	128M 256M MAX	Select DVMT5.0 Total Graphic Memory size used by the Internal Graphics Device.	
LCD Control	Disabled Enabled	LCD Control.	

### 3.3.2 PCH-IO Configuration

The North Bridge Screen allows user to set NB chipset configuration. To access this screen, form the Main screen, choose **Chipset-> PCH-IO Configuration**.

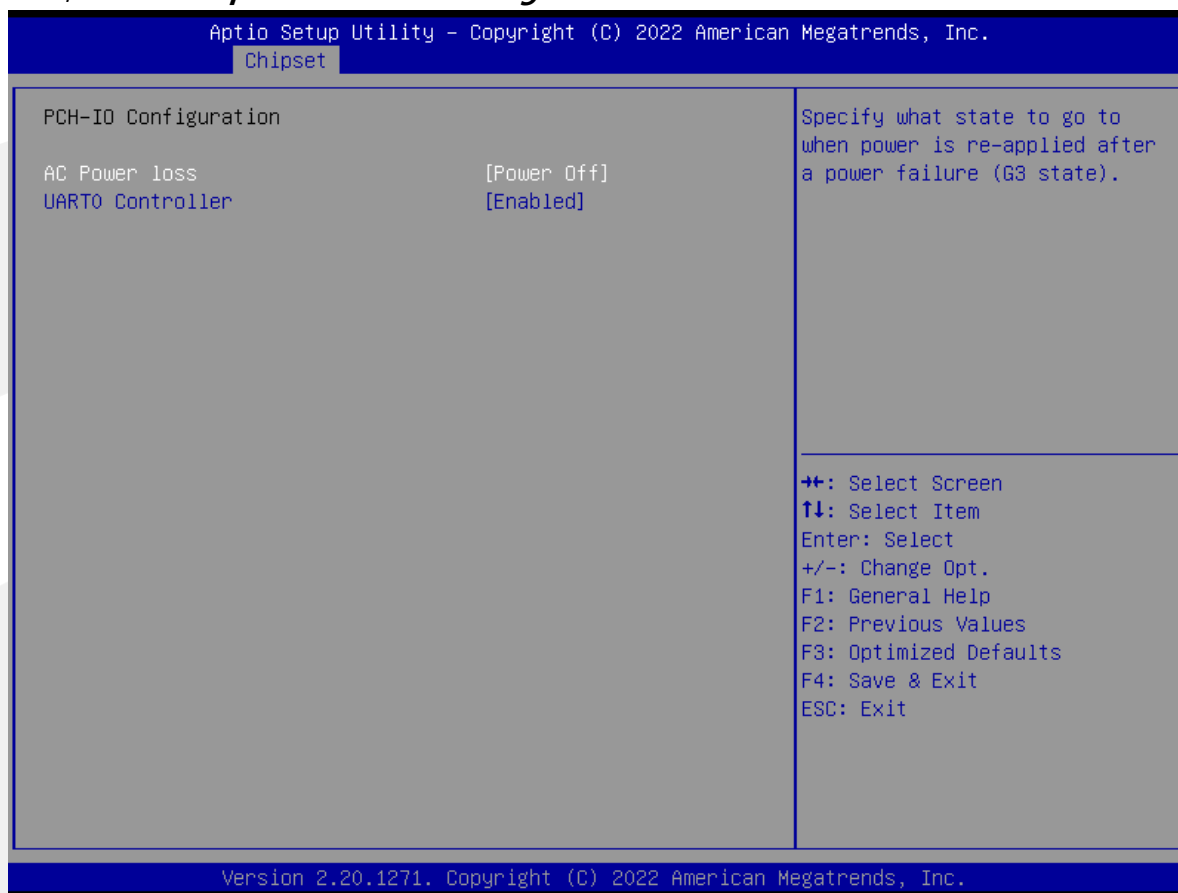

Setup Item	Options	Help Text	Comments
<b>PCH-IO Configuration</b>			
AC Power loss	Power On Power Off	Specify what state to go to when power is re-applied after a power failure(G3 state).	
UART0 Controller	Disabled Enabled	Enables/Disables Serial Io Controller The following devices depend on each other:I2C0 and I2C1,2,3 UART0 and UART1,SPI0,1UART2 and I2C4,5.	

### 3.4 Security

To access this screen form the Main screen, choose **Security**.



Setup Item	Options	Help Text	Comments
<b>Security</b>			
Administrator Password		Set Administrator Password.	
User Password		Set User Password.	

### 3.5 Boot Screen

The Boot screen displays any bootable media encountered during POST, and allows the user to configure desired boot device. To access this screen from the Main screen, choose **Boot**.



Setup Item	Options	Help Text	Comments
<b>Boot Configuration</b>			
Setup Prompt Timeout	1~65535	Number of seconds to wait for setup activation key.65535(0xFFFF) means indefinite waiting.	
Bootup NumLock State	On off	Select the keyboard Number state.	
Quiet Boot	Disabled Enabled	Enables or disables Quiet Boot option.	
<b>Boot Option Priorities</b>			
Boot Option #1		Sets the system boot order.	Note: Showed When boot devices existed.
Boot Option #2		Sets the system boot order.	
Boot Option #3		Sets the system boot order.	
New Boot Option Policy	Default Place First Place Last	Controls the placement of newly detected UEFI boot options.	
Hard Drive BBS Priorities		Set the order of the legacy devices in this group.	Set boot order in each group of the same kind, such as HDD, network.

### 3.6 Save & Exit Screen

The Save & Exit screen allows the user to choose whether to save or discard the configuration changes made on the other screens. It also allows the user to restore the server to the factory defaults or to save or restore them to set of user-defined default values.

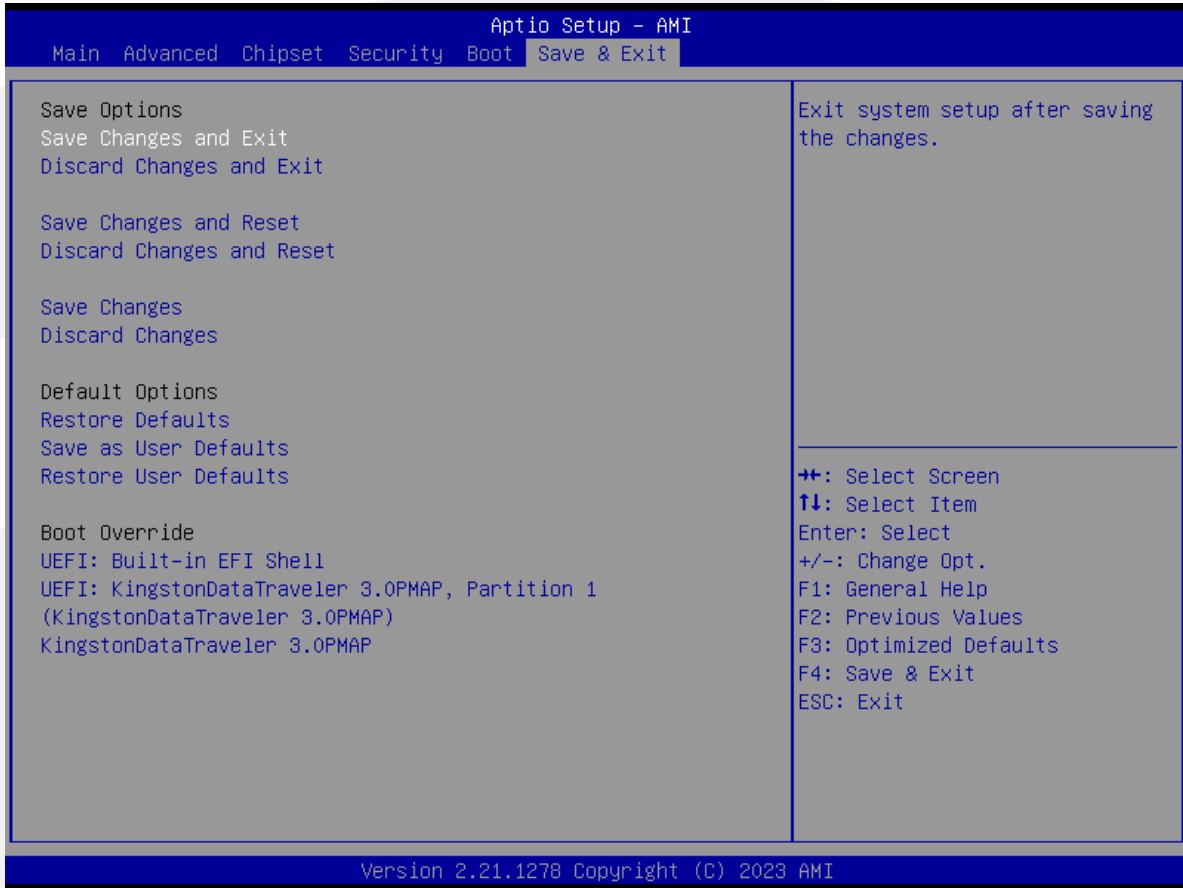

Setup Item	Options	Help Text	Comments
<b>Save &amp; Exit</b>			
<b>Save Options</b>			
Save Changes and Exit		Exit system setup after saving the changes.	User is prompted for confirmation only if any of the setup fields were modified.
Discard Changes and Exit		Exit system setup without saving any changes.	
Save Changes and Reset		Reset the system after saving the changes.	
Discard Changes and Reset		Reset system setup without saving and changes.	
Save Changes		Save Changes done so far to any of the setup options.	
Discard Changes		Discard Changes done so far to any or the setup options.	

Setup Item	Options	Help Text	Comments
<b>Default Options</b>			
Restore Defaults		Restore/Load Default values for all the setup options.	
Save as User Defaults		Save the changes done so far as User Defaults.	
Restore User Defaults		Restore the User Defaults to all the setup options.	
<b>Boot Override</b>			
Shows the Device can boot.			Note: Showed When boot devices existed.

## 第四章 Electrical Specifications

### 4.1 Input Power - General Considerations

The Compact, Basic and Extended Module Modules shall use a single main power rail with a nominal value of +12V. The Mini Module shall support a wide range power supply of 4.75V to 20.0V. In addition, the Mini Module shall be optimized for 5V operation and Module vendors should report Module power figures at 5V, 12V and 18V input voltages.

Two additional rails are specified: a +5V standby power rail and a +3V battery input to power the Module Real-time Clock (RTC) circuit in the absence of other power sources. The +5V standby rail may be left unconnected on the Carrier Board if the standby functions are not required by the application. Likewise, the +3V battery input may be left open if the application does not require the RTC to keep time in the absence of the main and standby sources. There may be Module specific concerns regarding storage of system setup parameters that may be affected by the absence of the +5V standby and / or the +3V battery.

The rationale for this power-delivery scheme is:

- Module pins are scarce. It is more pin-efficient to bring power in on a higher voltage rail.
- Single supply operation is attractive to many users.
- Lithium ion battery packs for mobile systems are most prevalent with a +14.4V output. This is well suited for the +12V main power rail.
- Contemporary chipsets have no power requirements for +5V other than to provide a reference voltage for +5V tolerant inputs. No COM Express Module pins are allocated to accept +5V except for the +5V standby pins. In the case of an ATX supply, the switched (non standby) +5V line would not be used for the COM Express Module, but it might be used elsewhere on the Carrier Board.

## 4.2 Input Power - Current Load

The Module connector pins limit the amount of power that can be brought into the COM Express Module. The limits are different for Module Pin-out Type 10 vs. Pin-out Types 6 and 7, based on the number of 12V power pins as Pin-out Type 10 has fewer pins available.

**Table 4.1: Input Power - Pin-Out Type 10 Modules (Single Connector, 220 pins)**

Power Rail	Module Pin Current Capability (Amps)	Nominal Input (Volts)	Input Range (Volts)	Derated Input (Volts)	Max Input Ripple (mV)	Max Module Input Power (w. derated input) (Watts)	Assumed Conversion Efficiency	Max Load Power (Watts)
VCC_12V	6	12	11.4 - 12.6	11.4	+/-100	68	85%	58
Wide input (Mini)	6		4.75 - 20.0	4.75	+/-100	28		
VCC_5V_SBY	2	5	4.75 - 5.25	4.75	+/-50	9		
VCC_RTC	0.5	3	2.0 - 3.3		+/-20			

**Table 4.2: Input Power - Pin-Out Type 6/7 Modules (Dual Connector, 440 pins)**

Power Rail	Module Pin Current Capability (Amps)	Nominal Input (Volts)	Input Range (Volts)	Derated Input (Volts)	Max Input Ripple (mV)	Max Module Input Power (w. derated input) (Watts)	Assumed Conversion Efficiency	Max Load Power (Watts)
VCC_12V	12	12	11.4 - 12.6	11.4	+/-100	137	85%	116
VCC_5V_SBY	2	5	4.75 - 5.25	4.75	+/-50	9		
VCC_RTC	0.5	3	2.0 - 3.3		+/-20			

The ripple voltage, if present, must not cause the input voltage range to be exceeded.

### 4.3 Input Power - Sequencing

COM Express input power sequencing requirements are as follows:

- VCC\_RTC shall come up at the same time or before VCC\_5V\_SBY comes up(if use)
  - VCC\_5V\_SBY shall come up at the same time or before VCC\_12V comes up(if use)
  - PWR\_OK shall be active at the same time or after VCC\_12V comes up(if use)
  - PWR\_OK shall be inactive at the same time or before VCC\_12V goes down(if use)
  - VCC\_12V shall go down at the same time or before VCC\_5V\_SBY goes down
  - VCC\_5V\_SBY shall go down at the same time or before VCC\_RTC goes down(if use)
- Wide input (Mini) shall follow the power sequencing of the VCC\_12V

**Figure 4-1: Power Sequencing**

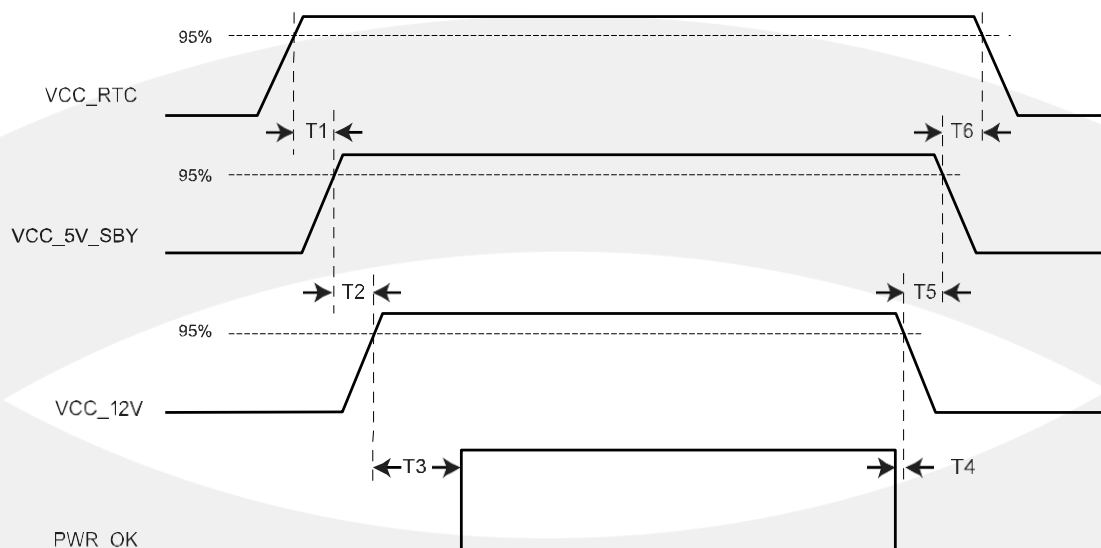

**Table 4.3: Power Sequencing**

T1	VCC_RTC rise to VCC_5V_SBY rise	$\geq 0$ ms
T2	VCC_5V_SBY rise to VCC_12V rise	$\geq 0$ ms
T3	VCC_12V rise to PWROK rise	$\geq 0$ ms
T4	PWR_OK fall to VCC_12V fall	$\geq 0$ ms
T5	VCC_12V fall to VCC_5V_SBY fall	$\geq 0$ ms
T6	VCC_5V_SBY fall to VCC_RTC fall	$\geq 0$ ms

## 4.4 Input Power - Rise Time

The input voltages to the COM Express Module VCC\_12V, wide input (Mini) and VCC\_5V\_SBY if used shall rise from  $\leq 10\%$  of nominal to within the regulation ranges within 0.1 ms to 20 ms ( $0.1 \text{ ms} \leq T_2 \leq 20 \text{ ms}$ ). There must be a smooth and continuous ramp of each DC output voltage from 10% to 90% of its final set point within the regulation band. The smooth turn-on requires that, during the 10% to 90% portion of the rise time, the slope of the turn-on waveform must be positive and have a value of between 0 V/ms and  $[\text{Vout, nominal} / 0.1] \text{ V/ms}$ . Also, for any 5ms segment of the 10% to 90% rise time waveform, a straight line drawn between the end points of the waveform segment must have a slope  $\geq [\text{Vout, nominal} / 20] \text{ V/ms}$ .

Figure 4-2: Input Power Rise Time

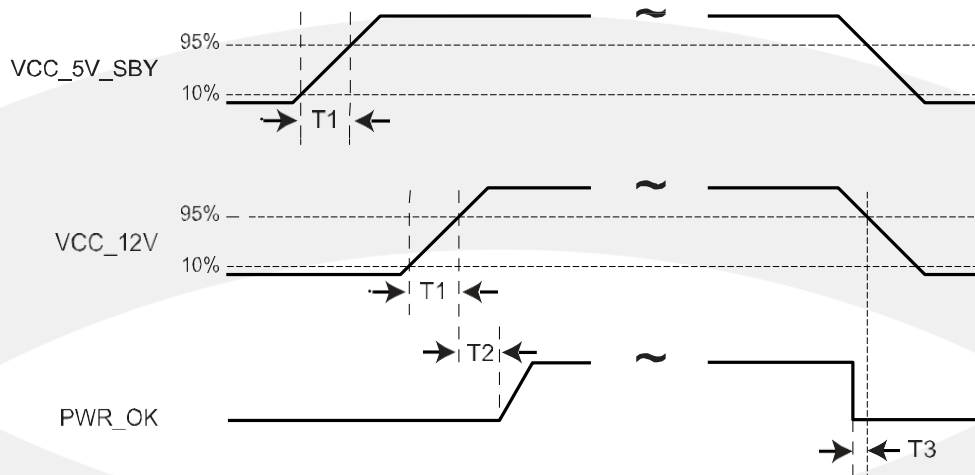

- $T_{1, \text{min}} = 0,1 \text{ ms}$
- $T_{1, \text{max}} = 20 \text{ ms}$
- $T_2 \geq 0 \text{ ms}$
- $T_3 \geq 0 \text{ ms}$

The values chosen were selected to be compatible and enable use of ATX specification R2.2.

## 4.5 Signal Integrity Requirements

The signal groups listed in the following table have signal-integrity concerns that should be accounted for in Module and Carrier Board designs. A general description is shown in the table for reference only. The designer should consult the relevant interface specification documents for complete information.

**Table 4.4: Signal Integrity Requirements**

Signal Group	General Description	Source Spec Reference
Gigabit Ethernet	Differential pairs	IEEE 802.3 Specification
LVDS	100Ω edge coupled differential pairs	National Semiconductor LVDS web site
PCI and LPC clocks	50Ω single ended ground-referenced	
PCI Express	Differential pairs	PCI SIG - PCI Express Specification
PCI Express clocks	100Ω edge couple differential pair, ground-referenced	
Serial ATA	Differential pairs	SATA Specification
USB	Differential pairs	USB 2.0 Specification
10GBASE-KR	Differential pairs	IEEE 802.3 Specification
USB SS	Differential pairs	USB 3.0 Specification
SPI	50Ω single ended ground-referenced	
eSPI	50Ω single ended ground-referenced	

## 附录

### 附一：术语表

#### ACPI

高级配置和电源管理。ACPI 规范允许操作系统控制计算机及其附加设备的大部份电能。

#### BIOS

基本输入/输出系统。是在 PC 中包含所有的输入/输出控制代码界面的软件。它在系统启动时进行硬件检测，开始操作系统的运作，在操作系统和硬件之间提供一个界面。BIOS 是存储在一个只读存储器芯片内。

#### BUS

总线。在计算机系统中，不同部件之间交换数据的通道，是一组硬件线路。我们所指的 BUS 通常是 CPU 和主内存元件内部的局部线路。

#### Chipset

芯片组。是为执行一个或多个相关功能而设计的集成芯片。我们指的是由南桥和北桥组成的系统级芯片组，他决定了主板的架构和主要功能。

#### CMOS

互补金属-氧化物半导体。是一种被广泛应用的半导体类型。它具有高速、低功耗的特点。我们指的 CMOS 是在主板上的 CMOS RAM 中预留的一部份空间，用来保存日期、时间、系统信息和系统参数设定信息等。

#### COM

串口。一种通用的串行通信接口，一般采用标准 DB9 公头接口连接方式。

#### DIMM

双列直插式内存模块。是一个带有内存芯片组的小电路板。提供 64bit 的内存总线宽度。

#### DRAM

动态随机存取存储器。是一个普通计算机的通用内存类型。通常用一个晶体管和一个电容来存储一个位。随着技术的发展，DRAM 的类型和规格已经在计算机应用中变得越来越多样化。例如现在常用的就有 SDRAM、DDR SDRAM 和 RDRAM。

#### I2C

Inter-Integrated Circuit 总线是一种由 PHILIPS 公司开发的两线式串行总线，用于连接微控制器及其外围设备。

#### LAN

局域网络接口。一个小区域内相互关联的计算机组成的一个计算机网络，一般是在一个企事业单位或一栋建筑物。局域网一般由服务器、工作站、一些通信链接组成，一个终端可以通过电线访问数据和设备的任何地方，许多用户可以共享昂贵的设备和资源。

## LED

发光二极管，一种半导体设备，当电流流过时它会被点亮，通常用来把信息非常直观地表示出来，例如表示电源已经导通或硬盘驱动器正在工作等。

## PnP

即插即用。允许 PC 对外接设备进行自动配置，不用用户手动操作系统就可以自己工作的一种规格。为实现这个特点，BIOS 支持 PnP 和一个 PnP 扩展卡都是必需的。

## POST

上电自检。在启动系统期间，BIOS 会对系统执行一个连续的检测操作，包括检测 RAM，键盘，硬盘驱动器等，看它们是否正确连接和是否正常工作。

## PS/2

由 IBM 发展的一种键盘和鼠标连接的接口规范。PS/2 是一个仅有 6PIN 的 DIN 接口，也可以用以连接其他的设备，比如调制解调器。

## USB

通用串行总线。一种适合低速外围设备的硬件接口，一般用来连接键盘、鼠标等。一台 PC 最多可以连接 127 个 USB 设备，提供一个 12Mbit/s 的传输带宽；USB 支持热插拔和多数数据流功能即在系统工作时可以插入 USB 设备，系统可以自动识别并让插入的设备正常。

深圳智锐通科技有限公司  
Shenzhen Zrt Co., Ltd.



智锐通公众号

&



智锐通抖音号

- 集团总部：深圳市宝安区碧桂园凤凰智谷A栋21楼
- 南京分公司：南京市江宁区万科都荟天地B2栋7楼
- 400-838-6869